

WARMAN®
Centrifugal Slurry Pumps

Excellent
Minerals
Solutions

WEHR
MINERALS

MC Pump range for Mill Circuit applications



Warman MC mill circuit duty slurry pumps are designed for the most aggressive duties and provide excellent wear life and reliability.



Warman 400 MCR
reverse rotation

Hydraulic experience and latest material technology make Warman MC the best choice for mill circuit applications

Warman MC pumps easily manage large size particles in dense abrasive slurries and are specifically designed for the most severe slurry applications such as ball and SAG mill cyclone feed plus water-flush crushing in mineral processing plants. They are also suitable for use as slurry transfer pumps on arduous applications such as gravel dredging or coarse coal cyclone feed.

MC pump hydraulics are based on more than 25 years of fundamental and applied research and backed up by wear performance field trials. Unique design and wear evaluation software ensures high efficiency and optimum life.

Warman MC designs incorporate the latest in hard alloy and elastomer technology, extending wear life in highly abrasive and corrosive slurries.

The MC range is engineered to enable different material combinations

MCR pump – elastomer liners inside ductile iron outer casing with metal impeller and metal or elastomer throatbush and frame plate liner insert

MCU pump – all metal unlined hard white iron casing with metal impeller, throatbush and frame plate liner insert

MCM pump – hard white iron metal liners inside ductile iron outer casing with metal impeller, throatbush and frame plate liner insert

- Large diameter, low speed, high efficiency impellers
- Latest wear resistant materials
- Interchangeable elastomer or metal liners, or unlined metal
- Simple full face side liner adjustment
- Self centring stuffing box design
- Fast one-piece wet-end changeout on larger sizes
- Reverse rotation also available to minimise wear in special sump orientations

Left: Chile's large copper plants continue to improve their installations. A 550 MCR pump has replaced a North American manufacturer

Middle: 450 MCR installed at a gold plant in North America

Right: Copper gold installation in Australia using the 550 MCR pump



Right: Three Warman 550 MCR mill circuit pumps installed at a copper mill along with Cavex hydrocyclones, Isogate slurry valves, and Vulco wear resistant rubber lined tanks, piping, hoses and spools



Engineered for severe duties, the Warman MC pump draws on years of proven mill circuit application experience

South American copper mines pioneered the use of rubber in large mill pumps and the majority of these plants now use Warman MCR elastomer pumps for mill discharge (cyclone feed) duties. In trial after trial, Warman elastomers have outperformed all competitors' cast metal pumps.

The advantages are many as Warman MCR elastomer liners:

- handle coarse particles and last longer
- handle ball scats with ease
- are lighter in weight and safer for maintenance
- are lower in cost than heavy metal parts

So whatever the preference – for a rubber or metal pump – the Warman MC pump will ensure the best wear life and operational safety.

Lined or unlined mill pump options ensure the optimum cost solution for your application

The outer casing of the lined MCM all metal pump ensures slurry containment and allows a safe shutdown in the event of a liner crack. This provides a low risk alternative to plants concerned with casing breakage due to mill ball overflow.

The unlined MCU metal range perfectly fits duties such as dense media circuit applications in the coal washing industry. Very thick metal casings, an impeller design for larger particle passing, and the full face adjustment feature ensure extended life with coarse coal slurries.

With the range of designs available, the MCU can be used in even the largest of the new high capacity coal washing plant installations. The MCU metal cased design can also be used for gravel pumping type applications. Longer wear life and lower operating costs are ensured.



Above top: A gold plant in Canada replaced a competitor's pump with a 150 MCR

Above bottom: 450 MCR at a copper installation in South America



Left: A large copper gold installation in Argentina has upgraded their existing 450mm pumps to the latest 450 MCR design



Left: Cover plate of a 550 MCR to be installed at a copper plant

Right: One of two new 550 MCU pumps installed at a copper plant in Brazil

Warman MC pump's unique design allows interchangeability of materials to optimise wear life

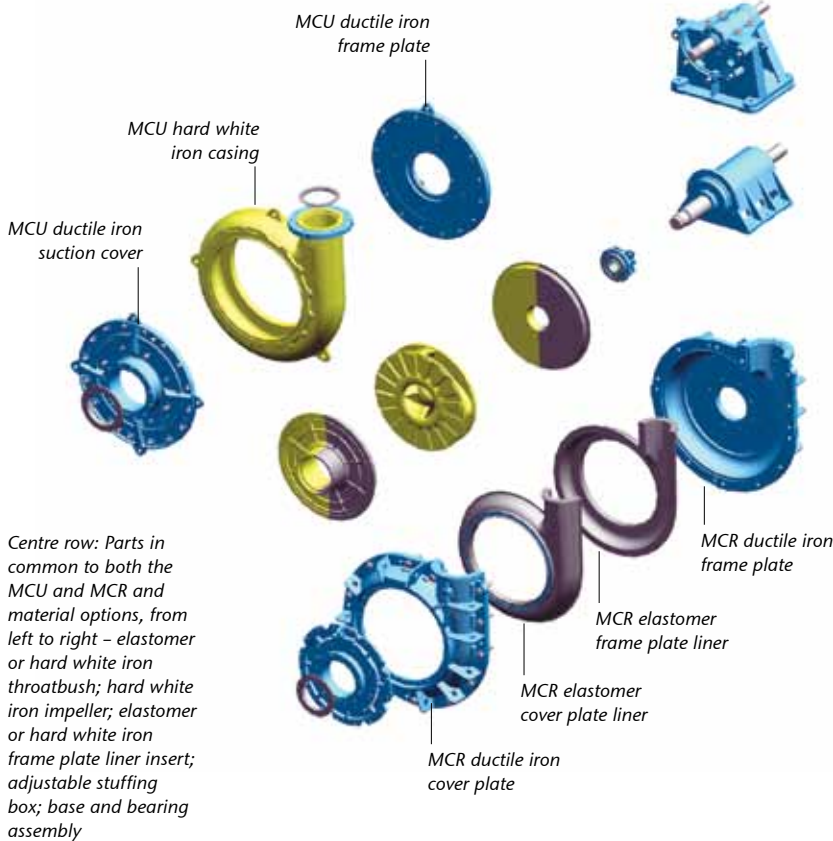

Only one pump manufacturer allows operators the flexibility of all-metal or all-rubber lined or a combination of both

The MC is the only pump for mill circuit applications that has interchangeable materials from a wide range of hard alloy and compression moulded elastomers. This enables optimum materials selection for each specific application ensuring the wear characteristics for each component are balanced.

Warman MC mill circuit duty slurry pump has a number of unique features

Reduced recirculation is achieved by the deep expelling vanes on the front of the hard alloy impellers. Expelling vane tip turbulence is minimised by the patented extended shroud feature that traps tip vortices and prevents localised scouring on the throatbush face.

Internal liners can be fully worn before replacement as the split outer casing provides structural integrity and high operating pressure capability and safety.

Split cover and frame plates allow easy access for replacement of the impeller and throatbush.

Two-piece coverplate on 400 MCR/MCM and larger for easy access to impeller, stuffing box, or complete inspection.

'Full face' adjustment extends wear life

The 'full face' adjustment feature allows the liner to move closer to the impeller face to minimize the impeller-throatbush gap

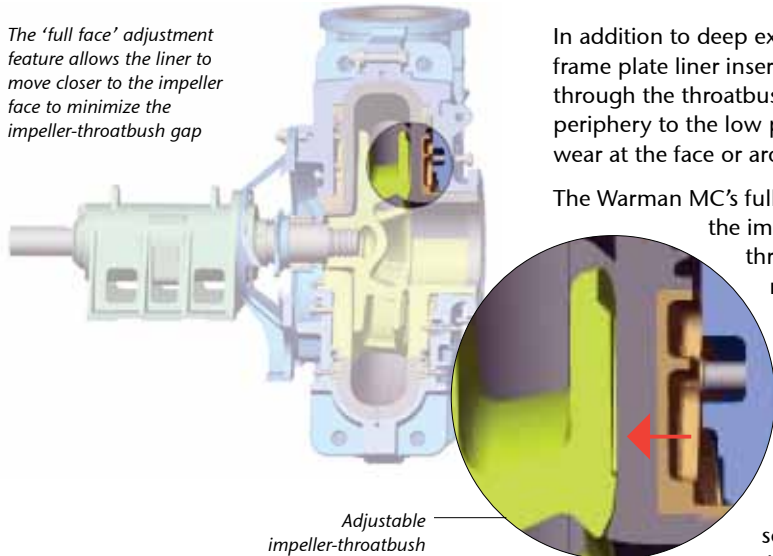

In addition to deep expelling vanes on the impeller, adjustable throatbush and frame plate liner insert are necessary to maximise part life. As slurry moves through the throatbush-impeller gap from the high pressure at the impeller periphery to the low pressure of the impeller eye, local high velocities can cause wear at the face or around the impeller eye.

The Warman MC's full face adjustment feature extends wear life by minimising the impeller-throatbush gap across the whole face of the throatbush. This provides gradual pressure reduction and minimal recirculation so any possible wear is distributed evenly, unlike sacrificial wear rings used by some manufacturers at the impeller eye that may focus wear and cause premature failure.

The full face double adjustment for throatbush and frame plate liner insert is easy to perform, even during operation, ensuring long liner life and optimum efficiency. Once clamping screws are released, adjusting screws can be rotated sequentially to move the liner closer to the impeller face.

‘One-piece’ wet end changeout ensures minimum mill downtime

Larger MC pump wet ends can be changed out and replaced as ‘one-piece’. By adjusting the throatbush and frame plate liner inserts tight against the impeller, mounting bolts can be removed, the impeller can be unscrewed from the shaft and the outer casing, liners and impeller pulled off as one-piece. Impeller and liner inspection can then be completed at a more convenient time in the workshop.



Stuffing Box Centring

Adjustable stuffing box allows for of the stuffing box and lantern restrictor to the shaft sleeve. This may be adjusted after piping loads have been applied to the pump to compensate for associated casing displacement.

Left: Orange centring tool pins align stuffing box to the sleeve



Above: A new innovative quick change procedure has been developed for faster removal of the larger MC range pump wet ends. A 650 MCR wet end being removed in Santiago, Chile

MC features save time and money

Easily adjustable throatbush allows maintenance of the impeller seal face clearance without the need to adjust bearing assembly or drive.

Easily adjustable frame plate liner insert allows maintenance of the drive side clearance and sealing performance to protect the stuffing box.

Large, open internal passages reduce internal velocities thus reducing wear.

A large diameter shaft with the shortest possible overhang and heavy duty roller bearings housed in a removable bearing cartridge extends bearing life.

Large diameter, low speed, high efficiency impeller manufactured from a range of abrasion resistant alloys provides increased wear life.

Patented shrouds that extend past the periphery of the impeller and expelling vanes provide improved flow and reduced wear at the expelling vane tips.

Patented casing profile with more material in areas of high particle impingement gives increased wear life.

Reversible casing (400MCR and larger) allows the discharge orientation to be either right vertical position (standard) or left vertical position, and so gives greater flexibility to the plant layout designer. The only additional parts required to effect the changeover are the clockwise rotation impeller and shaft.

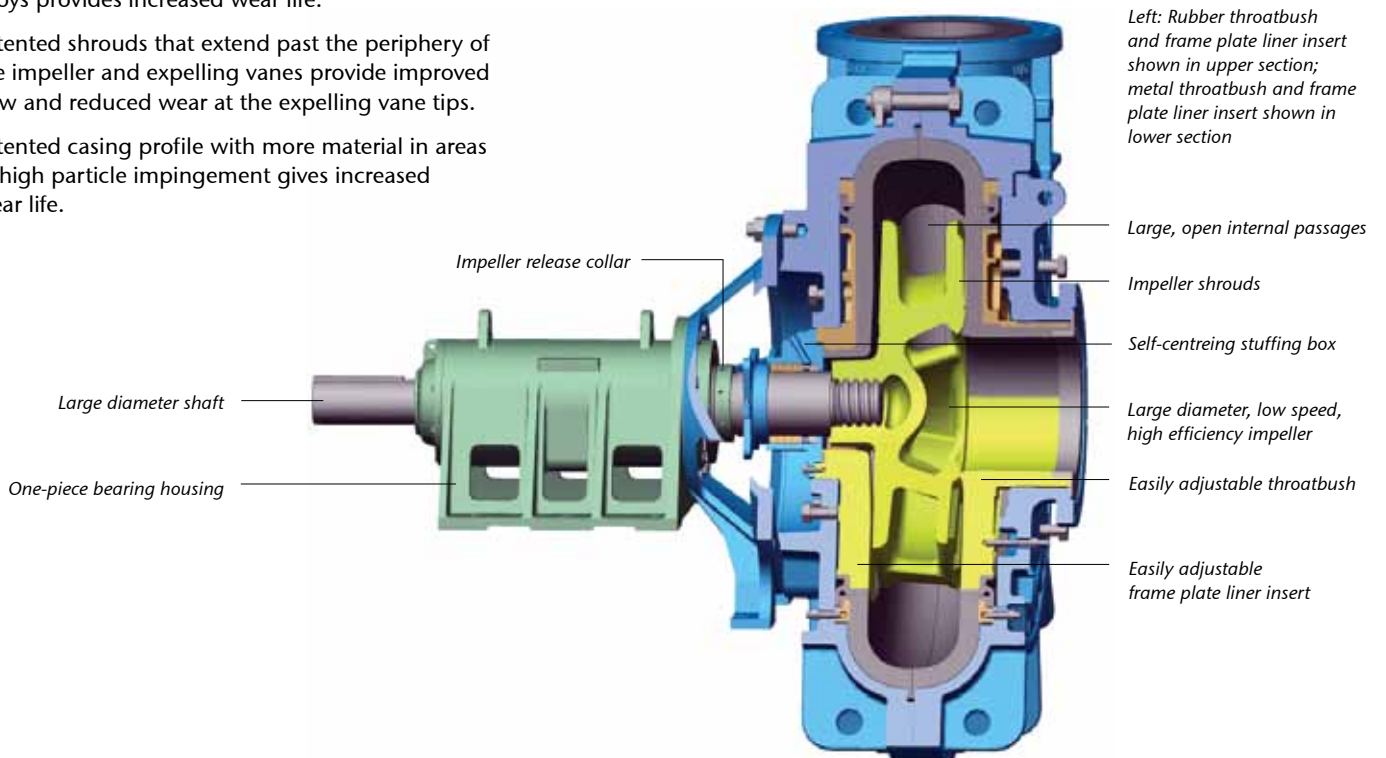

Warman MC mill circuit duty slurry pump is available in a range of sizes.

Right: A 550 MCR pump about to be installed at a copper plant in Chile

Far right: A 350 MCR which replaced a competitor's pump in Mexico



Left: 400 MCR pump undergoing performance testing at Weir Minerals North America test laboratory in Madison, Wisconsin



Below: 400 MCR pump after assembly at Weir Minerals North America. Pump destined for installation at a copper plant in Arizona



Product information software developed by Weir Minerals Pump Technology Centre

Weir Minerals product information software is available on CD from the local sales office or for download at weirminerals.com.

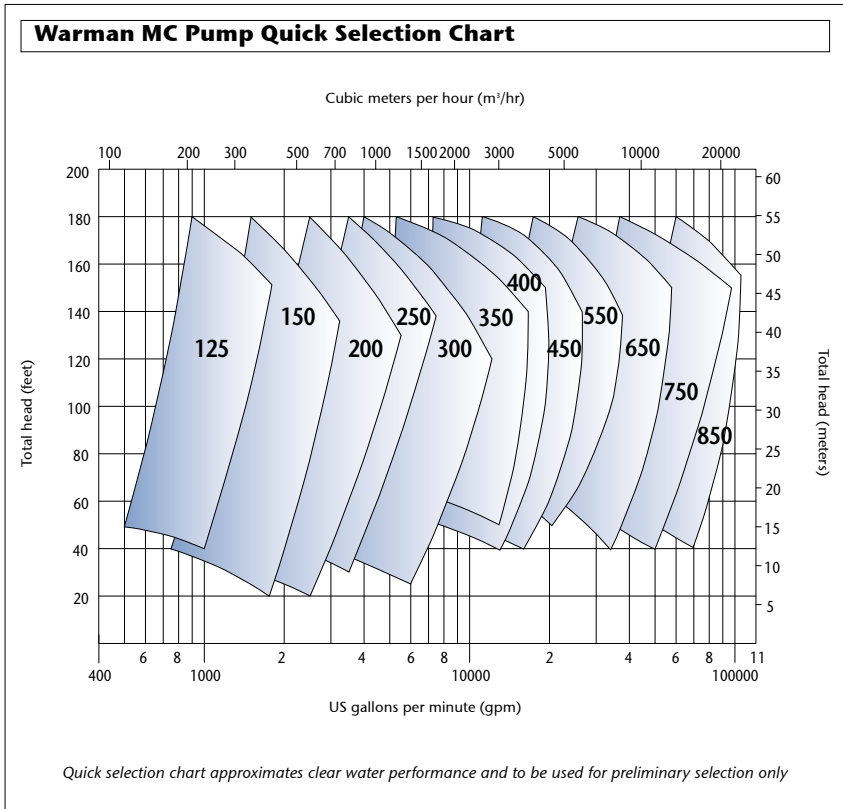

Three photos above: Sequence showing the fit up of a 400 MCR wet end

Above: 350 MCU for a large Russian iron ore dressing plant

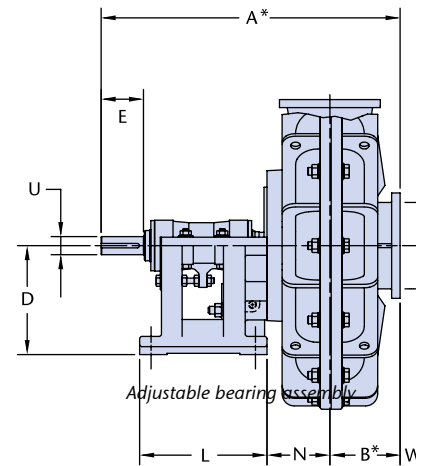
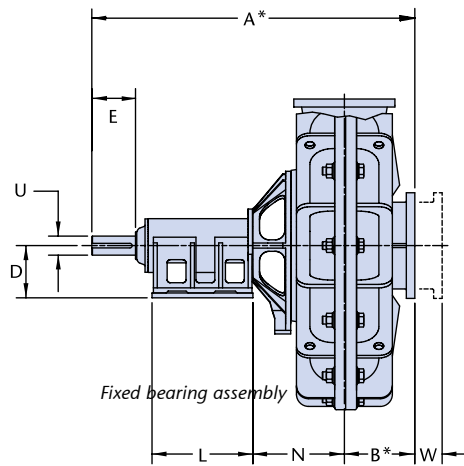
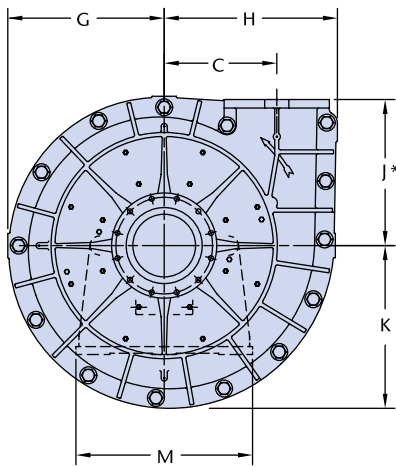

Warman MC Pump Dimensions (millimeters)

Fixed bearing assembly

Pump mm	Size	Type	Frame	A* mm	B* mm	C mm	D mm	E mm	G mm	H mm	J* mm	K mm	L mm	M mm	N mm	U mm	key size mm	W
125	(6x5)	MCH	M80	1240	206	240	205	220	378	412	385	384	380	620	389	80	22x14	64
150	(8x6)	MCU	M80	1283	243	351	205	220	533	569	532	554	380	620	190	80	22x14	400
200	(10x8)	MCR/U	M100	1670	335	485	255	290	700	728	745	740	453	880	547	100	28x16	460
250	(12x10)	MCR/U	M100	1742	390	560	255	290	824	868	850	847	453	880	563	100	28x16	350
300	(14x12)	MCR/U	M120	2142	381	629	310	316	940	1020	879	980	699	1048	651	120	32x18	870
350	(16x14)	MCR/U	M120	2168	404	697	310	316	1030	1123	970	1077	699	1048	655	120	32x18	390
400	(18x16)	MCR/U	M150	2541	510	801	405	344	1148	1281	1156	1199	770	920	687	150	36x20	450
450	(20x18)	MCR/U	M150	2485	580	930	405	344	1293	1431	1207	1345	770	920	761	150	36x20	850
550	(26x22)	MCR/U	M180	2870	680	1025	450	349	1406	1550	1322	1479	824	1200	880	180	45x25	850
650	(30x26)	MCR/U	M200	3323	758	1200	505	455	1645	1853	1554	1755	918	1340	1055	200	45x25	1200
750	(36x30)	MCR/U	M240	3678	850	1500	600	415	1918	2258	1850	2062	1000	1600	1180	240	56x32	1650
850	(40x34)	MCR/U	M240	3780	900	1500	600	415	1990	2320	2050	2090	1000	1600	1200	240	56x32	1800

Adjustable bearing assembly

Pump mm	Size	Type	Frame	A* mm	B* mm	C mm	D mm	E mm	G mm	H mm	J* mm	K mm	L mm	M mm	N mm	U mm	key size mm	W mm
125	(6x5)	MCH	EEAM	1200	206	240	457	222	378	412	385	384	448	622	240	85	22x14	64
150	(8x6)	MCU	EEAM	1247	243	351	457	222	533	569	532	554	448	622	265	85	22x14	400
200	(10x8)	MCR/U	FF	1670	335	485	610	290	725	752	745	740	705	990	383	120	32x18	460
250	(12x10)	MCR/U	FF	1742	390	560	610	290	824	868	850	847	705	990	399	120	32x18	350
300	(14x12)	MCR/U	GGAM	2010	381	629	851	357	940	1020	879	980	876	1219	393	150	36x20	870
350	(16x14)	MCR/U	TU	2262	404	697	900	350	1030	1123	970	1077	1050	1460	502	150	36x20	390
400	(18x16)	MCR/U	TU	2412	510	801	900	350	1148	1281	1156	1199	1050	1460	520	150	36x20	450
450	(20x18)	MCR/U	TU	2468	580	930	900	350	1293	1431	1207	1345	1050	1460	520	150	36x20	850
550	(26x22)	MCR/U	U	3180	680	1025	900	455	1406	1550	1322	1479	1375	1440	610	240	56x32	850
650	(30x26)	MCR/U	U	3343	758	1200	900	455	1645	1853	1554	1755	1375	1440	709	240	56x32	1200

* Includes compression of rubber flange joint.

Consult outline dimension drawings for size and location of mounting holes. Dimensions are for reference only.

Note: Casing dimensions are symmetrical around vertical centreline should the left vertical pump orientation be used.

Weir Minerals Australia Ltd

1 Marden Street
Artarmon NSW 2064
Australia
Tel: +61 2 9934 5100
Fax: +61 2 9934 5201

1/41 Kewdale Road
Kewdale WA 6105
Australia
Tel: +61 8 9366 2700
Fax: +61 8 9366 2777

www.weirminerals.com

Excellent
Minerals
Solutions

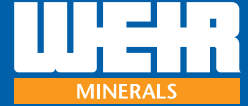

WARMAN®
Centrifugal Slurry Pumps

GEHO®
PD Slurry Pumps

VULCO®
Wear Resistant Linings

CAVEX®
Hydrocyclones

FLOWAY® PUMPS
Vertical Turbine Pumps

ISOGATE®
Slurry Valves

MULTIFLO®
Mine Dewatering Pumps

HAZLETON®
Specialty Slurry Pumps

LEWIS PUMPS™
Vertical Chemical Pumps

**BEGEMANN
PUMPS™**
Centrifugal Process Pumps

CAVEX, WARMAN, HAZLETON and MULTIFLO are registered trademarks of Weir Minerals Australia Ltd; LEWIS PUMPS is a registered trademark of Envirotech Pumpsystems Inc; GEHO and BEGEMANN PUMPS are registered trademarks of Weir Minerals Netherlands bv; FLOWAY is a registered trademark of Weir Floway Inc.; VULCO is a registered trademark of Vulco S.A.; ISOGATE is a registered trademark of Weir do Brasil Ltda.