

UNTHA

shredding technology

The reliable brand!



2-shaft-shredder
for reliable volume reduction



S25

EXAMPLES FOR UTILIZATION

- metal swarfs and plastic flakes
- metal and plastic punching waste
- metal and plastic pressure die casting
- metal and plastic barrels, canisters, cans
- light metal and plastic car bodies and parts
- wood, fruit boxes, small pallets
- carton and large-sized packaging materials
- cables and hoses
- PET bottles
- medical waste
- glass
- etc.

COMPACT AND MOBILE CRUSHING SYSTEM FOR RELIABLE VOLUME REDUCTION!

The UNTHA volume reduction system decreases your waste volume by up to 90%. As a result, you will be able to save on high costs for storage, transport and disposal.

In addition, the crushing system is often integrated in production processes to prepare the recovered raw materials for further processes.

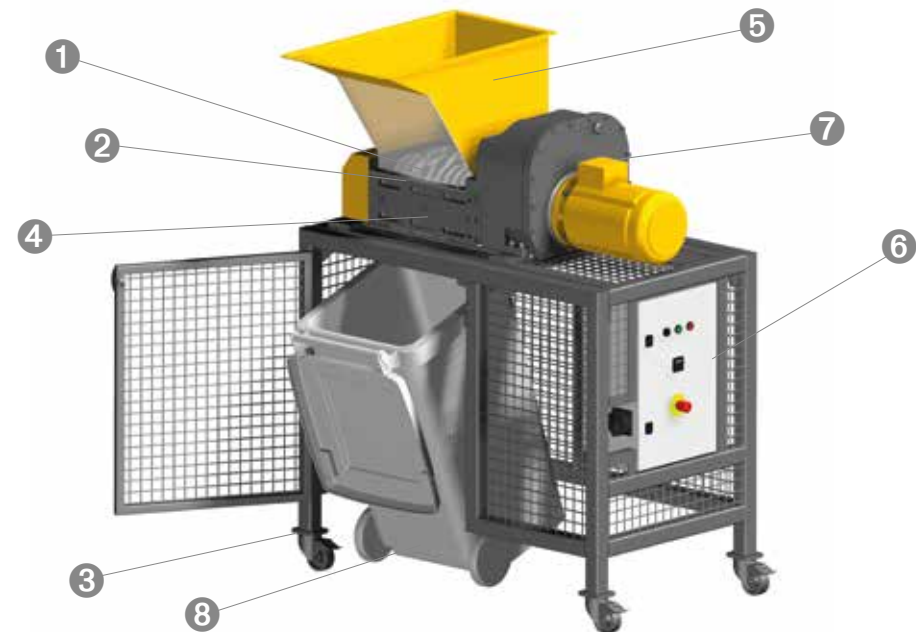

QUALITY FEATURES

- > slow running, low noise 2-shaft cutting system ①
- > robust, low wearing cutting discs ② from case-hardened high-grade steel
- > mobile substructure ③
- > robust, form-fitting screw-tightened machine body ④
- > stable steel hopper ⑤ including inspection window
- > control ⑥ directly at the system (reverse automatic, extra-neous material shutdown)
- > robust spur gear system incl. a low energy 7.5 kW drive motor ⑦
- > easily replacable collection bins ⑧
- > low maintenance since no hydraulics necessary
- > „Plug and shred,, - easy instalation

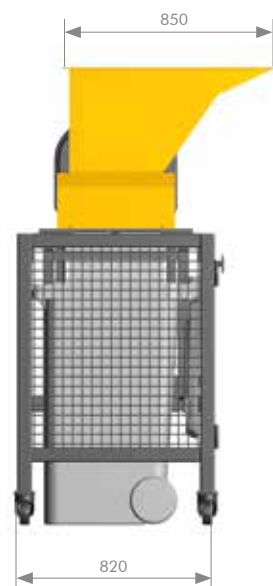
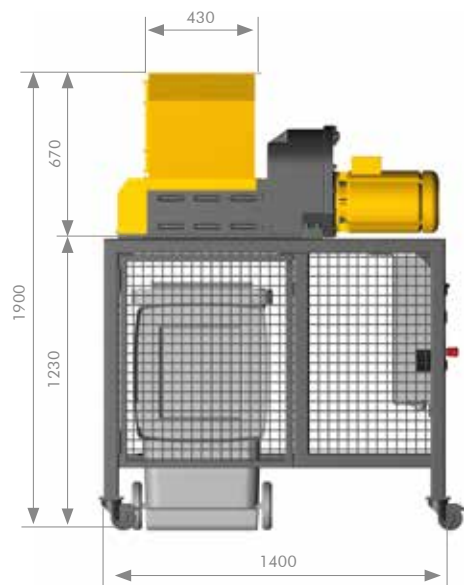

S25

2-shaft-shredding system

TECHNICAL DATA

Driving power	kW	7,5
Cutting system width	mm	430
Cutting system depth	mm	380
No. of cutting shafts	units	2
No. of cutters	units	23
Capacity Dustbin	litre	240
Weight	kg	750



shredding technology

The reliable brand!



UNTHA shredding technology

Kellau 141
5431 Kuchl / Salzburg, Austria
Tel +43 6244 7016 0
Fax +43 6244 7016 1
info@untha.com
www.untha.com

Authorised partner of UNTHA

