



SEPARATION

**SCREENING  
WITH EFFICIENCY**

Aqua-Screen FINE SCREENS

**ANDRITZ**

ENGINEERED SUCCESS

ANDRITZ fine screen technologies feature a wealth of benefits to meet the most demanding needs of our customers. The ANDRITZ Aqua-Screen fine screen, specially designed for handling municipal or industrial wastewater streams, ensures optimum separation of suspended solids from the water influent, thus supporting enhanced performance and operation of the downstream wastewater treatment process.

**THE BEST  
PROVEN  
SCREEN FOR  
YOUR NEEDS**

**ANDRITZ**

**ANDRITZ**



# One step forward in efficient screening

Proper screening is the first and one of the most important steps in a wastewater treatment plant (WWTP).

## WHAT DAMAGE DOES POOR SCREENING CAUSE?

Poor screening causes grit to accumulate in the clarifier and sludge processing equipment, thereby affecting the quality of the water. It also has a negative impact on the safety, maintenance, and operation of the WWTP, resulting in increased labor and maintenance costs and a reduction in WWTP efficiency.

## HOW TO SELECT THE RIGHT SCREENING TECHNOLOGY?

Critical parameters must be taken into account when selecting proper screening technology as each application or project is different. The following parameters are critical when selecting the correct equipment: application, flow, load, composition of screenings (sticky, fine, etc.), size of screenings, and so on. With more than 150 years of experience in the design and manufacturing of solid/liquid separation technologies, ANDRITZ can help you find the right solution to meet your specific screening requirements.

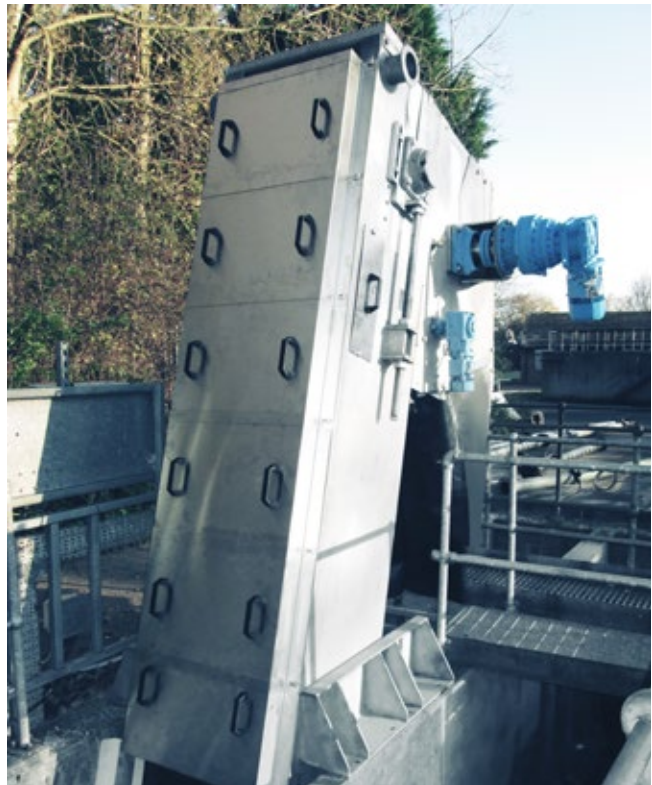

## YOUR BENEFITS

The ANDRITZ Aqua-Screen fine screen uses standardized and common frame parts. This design provides our customers with the following benefits:

- Reduced maintenance time
- Reduced number of different spare parts
- Operator-friendly adjustments with improved access door
- Pop-out/pop-in modular design for screen racks and panels (less than 30 minutes for complete replacement of filter element)
- Automatic detection of wear on supporting rail (on XL T version only)
- Automatic detection of drive chain tensioning (on XL version only)



# A modular concept for greater flexibility and cost savings

With its modular concept, the ANDRITZ Aqua-Screen fine screen is a high-tech solution adapted to your needs, integrating all existing screening categories:

- ANDRITZ Aqua-Screen T – Toothing system allows effective, two-dimensional fine screening and a lifting capacity (dimensions/quantity) unrivalled on the market; can be adapted to any application
- ANDRITZ Aqua-Screen P – Perforated plates system allows circular, two-dimensional fine screening – one of the most efficient on the market; can be adapted to most applications

Depending on the screening system selected, the ANDRITZ Aqua-Screen fine screen can achieve a capture rate of up to 85%. A high capture rate improves maintenance costs by preventing high solids content reaching the downstream equipment (pumps, impeller, aeration turbines, and aeration compressors).

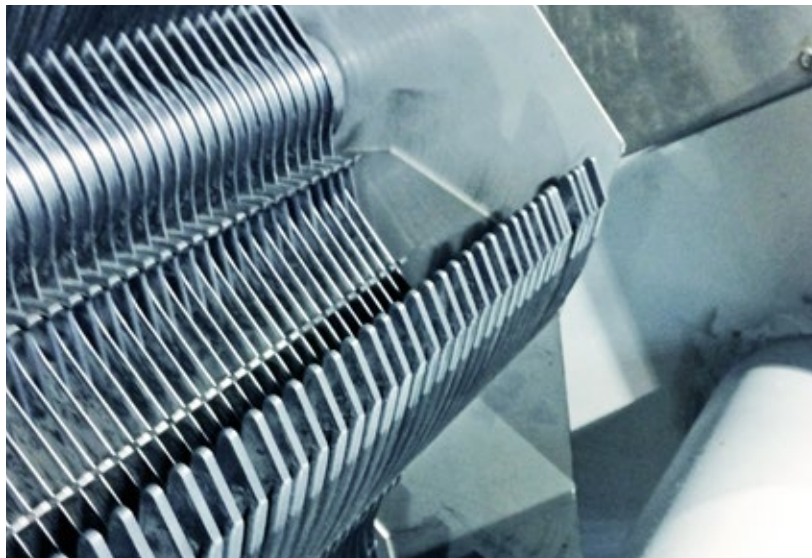

ANDRITZ Aqua-Screen T fine screen



ANDRITZ Aqua-Screen P fine screen

# Common frame for ease of maintenance

The ANDRITZ Aqua-Screen fine screen technology features our slide-out/slide-in modular design for the filter elements.

## FRONT DISMANTLING

The ANDRITZ Aqua-Screen fine screen features a front-end access door. The complete rack holding the filter elements can be removed in one step through this access point. This means that downtime is reduced to a minimum, typically taking less than 30 minutes for a field service technician to change the filter elements.

In addition to the time saved, this maintenance-friendly design, requires much fewer steps and parts to complete the operation of changing the screen filter.

## ISM – INTELLIGENT, SIMPLIFIED MAINTENANCE

An innovative maintenance concept has been developed for the ANDRITZ Aqua-Screen fine screen and comes as standard on large models: ISM (Intelligent, Simplified Maintenance). The ISM system allows preventive maintenance by monitoring rail wear and chain tensioning. Sensors inform the operator before failures occur – this not only protects the equipment and plant, but also limits maintenance costs and reduces downtime.



Filter element can be dismantled from the front

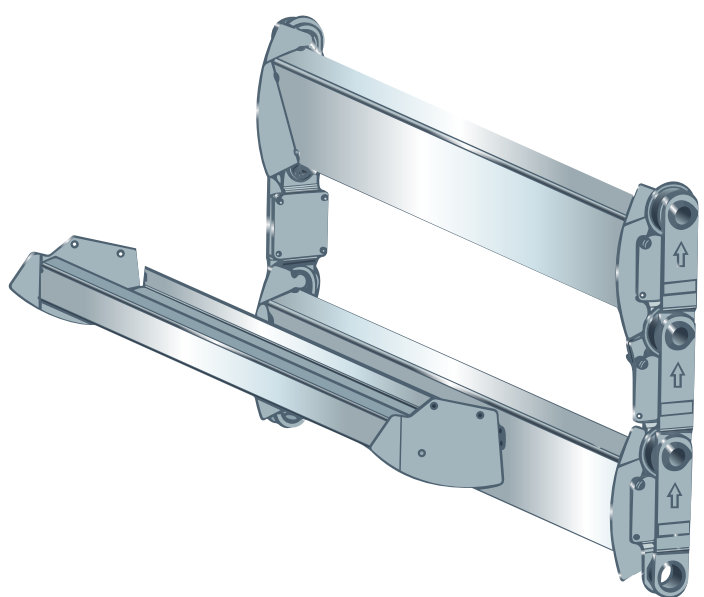
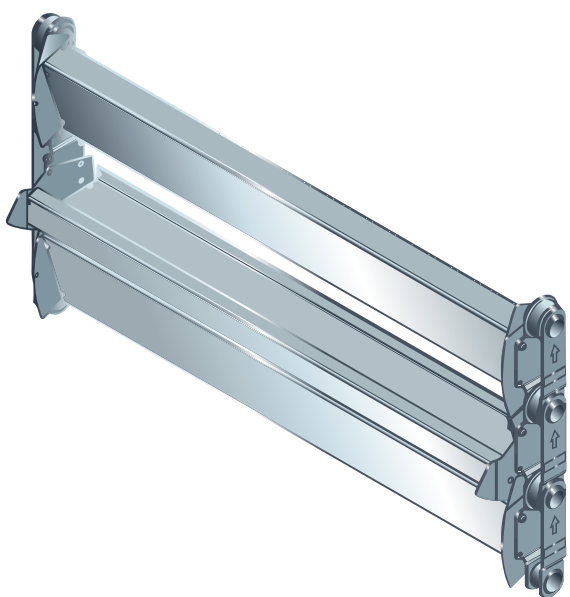

Less than 30 minutes to change the filter elements



# Self-washing, continuous fine screen – the ANDRITZ Aqua-Screen T

With more than 6,000 references delivered over more than 40 years, and recognized as the most efficient headwork screen, the ANDRITZ Aqua-Screen T fine screen is one of the most reliable screening technologies available on the market today.

Working on the same principle as an escalator, the ANDRITZ Aqua-Screen T fine screen lets the influent flow through its mesh of filter elements made of replaceable teeth.

The teeth and their supporting rack create a bi-dimensional filtering mesh, making it the ideal option for any front-end screening installation. Bi-dimensional separation provides high efficiency in terms of capture and is improved by a lifting system that prevents the screened particles from breaking up during removal. The filter element is shaped as a hook; this not only allows particles of different sizes to be removed, but can also accommodate uneven capacity in terms of volume. In addition, the long peak of the filter element can remove large items – a unique feature in fine screening equipment.

The filter elements are made of acrylonitrile butadiene styrene (ABS). ABS is a material that can absorb shocks and return to its original position and shape. This unique system based on these retractable teeth makes the Aqua-Screen T fine screen one of the most efficient self-cleaning screens.

As the toothed filter elements travel around the screen, a specific self-cleaning mechanism is created by the retracting movement of the teeth. This displacement removes any fiber, screenings, or solids left on the filter element. Then a specially designed brush assisted by a wash water spray also scrapes any sticky or fine solids off the filter elements.

## YOUR BENEFITS

- Pop-out / pop-in modular filter racks that can be replaced easily from the front of the screen with optimum accessibility for ease of maintenance
- Improved teeth design allowing increased screening and lifting capacity
- Improved capture rate
- Optimal efficiency thanks to bi-dimensional separation and unmatched lifting capacities (dimensions/quantity)
- Fewer wear parts means reduced maintenance costs
- Versatility in combination with Aqua-Screen P fine screen (possible to convert from one model to the other to improve the capture rate)
- No submerged bearing for maintenance ease and increased lifetime
- Can be adapted to handle the most challenging applications
- Also available in off-channel, tank-mounted version



# High capture rate with ANDRITZ Aqua-Screen P perforated-plate fine screen

Building on our extensive experience with other screening technologies, ANDRITZ has developed the ANDRITZ Aqua-Screen P fine screen, a perforated-plate fine screen. It allows high capture rates of up to 85% – the best level ever achieved for headworks in WWTP.

The ANDRITZ Aqua-Screen P fine screen is a fine screen with a continuous belt that can be easily installed in any type of channel. Working on the same principle as an escalator, the ANDRITZ Aqua-Screen P fine screen lets the flow circulate through it, at the same time allowing separated elements to travel back up by using an exchangeable perforated plate. The perforated plate has steps every 10 to 20 cm, enabling it to handle larger elements and provide greater removal capacity compared to conventional perforated screens. The P version optimizes the screening capture rate thanks to its circular mesh, while the lifting system prevents screened particles from being broken up when they are removed. To eliminate undesirable elements from the screen, an adjustable, rotating brush is used to increase cleaning performance, assisted by a bi-directional spray ramp system at the rear of the machine.

## YOUR BENEFITS

- Circular mesh allowing the best capture rate in fine screening
- Separation in two dimensions for higher capture rate (the same mesh vertically and horizontally)
- Double cleaning system outside the filtration area, allowing optimal efficiency
- Perforated plate has a modular design, thus fewer spare parts are needed and the supply chain is shortened
- Versatility in combination with ANDRITZ Aqua-Screen T fine screen (possible to convert from one model to the other to improve lifting capacity)
- No submerged bearing for maintenance ease and increased lifetime
- Increased cleaning performance thanks to adjustable cleaning brush and bi-directional spray ramp





# Best-in-class MBR protection with ANDRITZ Aqua-Screen MBR fine screen

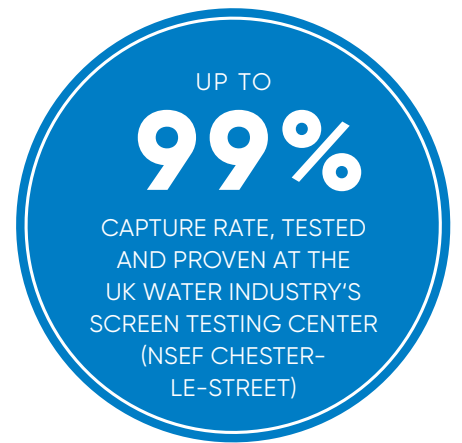

In addition to the modular screen system, the ANDRITZ range includes a complementary device for MBR (Membrane BioReactor) protection – the ANDRITZ Aqua-Screen MBR fine screen. In order to protect the MBR, it is essential to eliminate any kind of fibrous material, which could damage and clog the system. The ANDRITZ Aqua-Screen MBR fine screen has a capture rate of up to 99%.

The ANDRITZ Aqua-Screen MBR fine screen is installed after a 5 to 15 mm screening device or after clarification processes. Filtration is accomplished by using an inclined conical drum that is perforated with holes ranging from 1 to 3 mm, depending on the process. The material is conveyed by an endless screw that is welded to the drum, eliminating any friction and preventing the recovered particles in the conveyor from breaking up. To ensure continuous operation and filtration efficiency, the perforated drum is cleaned by an external spray ramp. An innovative, inclined internal gutter collects the screenings and wash water. The wash water is used to convey the screenings directly to the end of the filtration zone, freeing up the screening area from incoming screenings very rapidly and providing efficient filtration, even at peak organic load levels. The mix of water and slurry extracted by the ANDRITZ Aqua-Screen MBR fine screen can be collected directly in a fully integrated compactor named Rotodry to compact the screenings; the screenings can also be conveyed by a pump or conveyor to be dewatered in another system.

The following features are provided:

- Three functions: filtration, conveying, and compacting
- Holes range from 1 to 3 mm
- Channel-mounted (excl. AD250)
- Compliant with CE machine standards

The ANDRITZ Aqua-Screen MBR fine screen is applied for:

- MBR protection
- Extra-fine screening for removal of fibrous materials in tanneries, laundries, vegetable cleaning plants, etc.



ANDRITZ Aqua-Screen MBR fine screen for Membrane BioReactor protection

## YOUR BENEFITS

- Best capture efficiency thanks to the perforated drum with circular holes
- One-piece drum design has high stress resistance compared to a segmented construction
- Unique conveying gutter ensures maximum recovery of all screenings and transfer to the end of the filtration zone
- Ease of maintenance (roller-guided drum, dismountable without tools within only 30 minutes, the front brush can be replaced without dismantling the drum, and no greasing is necessary as the guide rollers have lifetime grease lubrication)
- Integrated, high-efficiency compactor
- Continuous waste extraction without any rotating, external components to increase reliability

# Product range and applications

The ANDRITZ Aqua-Screen fine screen range ensures maximum availability with minimum maintenance and can be customized for a variety of solid/liquid separation processes. Thousands of customers across the globe rely on the ANDRITZ Aqua-Screen MBR fine screen as an indispensable part of their process – whether in wastewater treatment plants serving entire cities, at large-scale textile manufacturers, or at family-run craft breweries.

## APPLICATIONS

### Municipal

- Screening at inlet of sewage treatment plants
- Fine screening ahead of sludge treatment, biofilters, septic sludge
- Membrane protection

### Water intake

- Rivers
- Lakes
- Seawater

### Industrial

- Pulp and paper
- Textile industry
- Tanneries, bleaching, dyeing, etc.

### Food processing

- Meat processing, slaughterhouses
- Vegetable and fruit processing
- Food industry
- Wineries, breweries, etc.

## ANDRITZ Aqua-Screen T AND P FINE SCREENS

Model	Version L		
Width	500	750	1,000
Height	1,500 to 7,000 (pitch of 500)		
Channel height	1,500 to 6,000		
Mesh Aqua-Screen T	1, 3, 6, 10, and 15		
Mesh Aqua-Screen P	3 and 6*		
Material	304L or 316L*		

Model	Version XL				
Width	900	1,200	1,500	1,800	2,100
Height	2,500 to 10,000 (pitch of 500)				
Channel height	1,500 to 9,000				
Mesh Aqua-Screen T	1, 3, 6, 10, and 15				
Mesh Aqua-Screen P	3 and 6*				
Material	304L or 316L*				

\* Others upon specific request

## ANDRITZ Aqua-Screen MBR FINE SCREENS

Model	Mesh diameter (mm)	Suspended solids content (mg/l)	Flow (m <sup>3</sup> /hr)**
AD 250	1 to 3	<600 mg/l	200 to 400
AD 500	1 to 3	<600 mg/l	250 to 800
AD 1000	1 to 3	<600 mg/l	500 to 3,000

\*\* Capacity linked to screening mesh, load, and upstream screening protection mesh





# Your full-service provider

With ANDRITZ, you gain access to one of the world's largest OEM manufacturers for solid/liquid separation systems, including such well-known brands as 3Sys Technologies, Bird, Delkor Capital Equipment (Pty) Ltd., Escher Wyss dryers, Frautech, Guinard Centrifugation, KHD Humboldt Wedag, Krauss-Maffei centrifuges, dryers, and filters, Lenser, Netzsch Filtration, Rittershaus & Blecher, Royal GMF Gouda, Sprout Bauer, and Vandebroek.

Whether you need spare parts, rentals, local service, repairs, upgrades, or modernization of your equipment, ANDRITZ is your true full-service provider. From initial consulting through to service agreements, process optimization, and training programs, we are always looking for ways to minimize downtime and increase predictability in operations while raising your overall production efficiency. Wherever you operate, our network of 550 service specialists and global service centers ensures we'll always be there to support you for many life cycles to come. Let's sit down and see how we could take your operations to the next level.



#### LOCAL SUPPORT

Responsive local service centers and field service technicians



#### REPAIRS & UPGRADES

Optimization of machine and process performance, repair work, retrofitting, and modernization



#### SECOND-HAND & RENTALS

Certified second-hand and rental machines



#### TRAINING

Operator training and tailored seminars for operating and maintenance personnel



#### OEM SPARE PARTS

Filter cloths, spare and wear parts from OEMs or with OEM level quality, all readily available



#### SERVICE AGREEMENTS

Preventive maintenance, contracts for spare parts, maintenance, inspections, repairs, upgrades, operation, and equipment monitoring



#### PROCESS OPTIMIZATION

Automation tools and process expertise to boost your profit



#### LAB AND ON-SITE TESTS

Lab and testing capabilities for process optimization and machine upgrades





## WHAT'S YOUR SEPARATION CHALLENGE?

ANDRITZ Separation is the world's leading separation specialist with the broadest technology portfolio and more than 2,000 specialists in 40 countries. For more than 150 years, we have been a driving force in the evolution of separation solutions and services for industries ranging from environment to food, chemicals, and mining & minerals. As the OEM for many of the world's leading brands, we have the solutions and services to transform your business to meet tomorrow's changing demands – wherever you are and whatever your separation challenge. **Ask your separation specialist!**

### AFRICA

ANDRITZ Delkor (Pty) Ltd.  
p: +27 11 012 7300  
separation.za@andritz.com

### EUROPE

ANDRITZ S.A.S.  
p: +33 1 39 26 05 50  
separation.fr@andritz.com

### ASIA

ANDRITZ Singapore Pte. Ltd.  
p: +65 6512 1800  
separation.sg@andritz.com

### NORTH AMERICA

ANDRITZ Separation Inc.  
p: +1 817 465 5611  
separation.us@andritz.com

### AUSTRALIA

ANDRITZ Pty. Ltd.  
p: +61 3 8773 4888  
separation.au@andritz.com

### SOUTH AMERICA

ANDRITZ Separation Ltda.  
p: +55 47 3387 9100  
separation.bra@andritz.com

### CHINA

ANDRITZ (China) Ltd.  
p: +86 757 8258 6802  
separation.cn@andritz.com

**ANDRITZ.COM/SEPARATION**



All data, information, statements, photographs, and graphic illustrations in this leaflet are without any obligation and raise no liabilities to or form part of any sales contracts of ANDRITZ AG or any affiliates for equipment and/or systems referred to herein. © ANDRITZ AG 2018. All rights reserved. No part of this copyrighted work may be reproduced, modified, or distributed in any form or by any means, or stored in any database or retrieval system, without the prior written permission of ANDRITZ AG or its affiliates. Any such unauthorized use for any purpose is a violation of the relevant copyright laws. ANDRITZ AG, Stattegger Strasse 18, 8045 Graz, Austria. Aqua-Screen 2.0/12.2018 EN