

Digital industrial charge amplifier

Type 5074A...

Charge amplifier for systems based on Industrial Ethernet

Kistler's Type 5074A... is a universal industrial charge amplifier for piezoelectric sensors. It allows reliable and precise capture of dynamic and quasi-static processes. This amplifier supports the main Industrial Ethernet standards, depending on which it offers real-time measurement with extremely fast cycle times as well as several special data acquisition functions that are configurable for specific applications.

- Versions with 1, 2, 3 or 4 channels
- Wide measurement range from 20 pC to 1 000 000 pC
- Versions for EtherCAT, PROFINET and EtherNet/IP
- Variable process map to optimize network capacity utilization
- Internal 24-bit data acquisition
- Real-time output in cycles up to 100µs per channel
- Support for oversampling and synchronization enables output of up to 50 kSps per channel
- Flexible low-pass filter and switchable high-pass filter
- Peak value acquisition
- Calculation of integral value
- Sensor signal scaling
- Network and channel status indicators
- Handshake for device status changes
- Configuration via standard control programming interface, no additional software required
- Cascadable design; multiple bus participants can be connected consecutively
- Protection class IP67 with FKM/FPM sealing elements

Description

Kistler's Type 5074A... offers real time-capable acquisition of piezoelectric signals in the most widespread types of Industrial Ethernet, with communication exclusively via this interface. The 5074A... delivers high performance with transmission at up to 50 kSps per channel. This creates the possibility of real-time transmission of measurement data with cycle times as short as 100 µs, so critical process controls can also be implemented. No data is stored permanently on the 5074A... . All the settings are located on the control, so the customer also has guaranteed data sovereignty. The adjustable low-pass filter means that targeted smoothing of interference signals is already implemented in the amplifier. The switchable high-pass filter¹⁾ allows monitoring of fast processes without interrupting the measurement – even during continuous operation. Analog measurands are already digitized in the amplifier. Combined with the integrated electrical isolation in the 5074A..., this early digitization enables reliable, interference-resistant delivery of measurement values to the master system.



Applications

The Type 5074A... was specifically developed for use in modern, fast Industrial Ethernet systems. This amplifier's high performance makes it suitable for various tasks such as real-time control in joining and cutting processes as well as high-resolution process recording for injectors and pressure pulsation measurements. Protection class IP67 and sealing elements made of FKM/FPM also allow decentral use in more difficult conditions outside the control cabinet with fluid media, various gases and some alkalis.

Influencing and adapting the process map

Conditioning large numbers of analog values with short cycle times can massively increase network capacity utilization. The Type 5074A... allows flexible adaptation of the process map, so network utilization can be optimized in line with customers' requirements.

Possible measures to reduce the process map include:

- Use 16-bit values instead of 32-bit
- Switch off functions that are not needed (floating point, integral and peak values)

Changes to the measuring channel configuration are adopted in the next measuring cycle at the earliest; they are confirmed to the master with the 'Parameter active' status bit.

¹⁾ The filter frequency for the high-pass filter depends on the measurement range that is set

5074A_003-332e-09:17

Scaling the input signals

The 'Scaling Divisor' parameter is used to scale the input variable. Typically, the measuring element's sensitivity as shown on the calibration certificate is entered for the divisor. The transmitted 32-bit REAL measurement values therefore correspond to the physical variable according to the calibration of the measuring element. In addition, the 16-bit integer values are scaled with the final range value, so they then correspond to classical input values.

Adjusting the measurement range

The measurement range is adjusted with the 'Range' parameter, with two basic functions. The 5074A has 3 internal measuring segments per channel. Depending on the range adjustment, the best possible segment is selected to guarantee maximum precision across multiple decades. In addition, the measuring range final value scales the measured integer values to 16-bit.

Adjustable low-pass filter

The low-pass filter is calculated by internal signal conditioning in the FPGA. The required filter frequency can be selected from predefined values for the 'Filter-Frequency' parameter. Lower filter frequencies lengthen the signal delay.

Oversampling factor

An oversampling factor can be applied to 16-bit measurement values in order to record and analyze signals where network cycles are too slow. Depending on the factor that is set, the network interval is divided into as many as 50 sub-intervals per channel; additional measurement values are recorded and a precise time stamp can be assigned to them by the control. Due to its massive influence on the process map, the oversampling factor only acts on the scaled 16-bit integer values.

Time constant

The switchable time constant is a high-pass filter that operates directly in the analog hardware. The measurement signal is reduced towards zero according to a capacitor discharge curve.. The time constant depends on the selected measurement range and cannot be changed.

Peak value tracking

Peak values are controlled via the cyclical 'Peak control' output parameters, and they can also be reset while the measurement is ongoing. For instance, this feature can be used to monitor process phases during the active measurement. According to choice, peak value acquisition can be unfiltered, or can use the filter selected for each channel. In this way, interference signals can either be acquired or filtered out on an application-specific basis.

Integral function

The integral function is controlled via the 'Integral control' parameter. It can also be switched while the measurement is active. The high data rate increases the precision of the internal calculation, relieving pressure on the customer's system.

Technical data

Charge amplifier

Number of channels		1, 2, 3, 4
Measurement range per channel (FSO)	pC max.	±20 ... 1 000 000
Measurement error with FSO ≥100 pC	% FSO	<±0,5
Measurement error with FSO <100 pC	% FSO	<±1,0
Drift		
25 °C, max. relative humidity (rh) of 60%, non-condensing	pC/s	<±0,05
25 °C, max. relative humidity (rh) of 70%, non-condensing, typ.	pC/s	<±0,05
50 °C, max. relative humidity (rh) of 50%, non-condensing	pC/s	<±0,3
Reset-Operate transition	pC	<±2
Input signal without damage: voltage (constant)	V	±10
Frequency range		
Q <900 pC (Cg = 200 pC) (-3 dB, cable capacitance <1 nF)	kHz	»0 ... <20
Q <31k pC (Cg = 7 nF) (-3 dB, cable capacitance <1 nF)	kHz	»0 ... <10
Q <1M pC (Cg = 240 nF) (-3 dB, cable capacitance <1 nF)	kHz	»0 ... <2
Operate-Reset time		
Q <900 pC	us	<100
Q <31k pC	us	<300
Q <1M pC	ms	<10
Reset-Operate time	us	<20
Hardware high-pass filter, typ. (time constant)		
Q <900 pC	s	0,03 (±6%)
Q <31k pC	s	1,05 (±6%)
Q <1M pC	s	36 (±7%)
Input-referred noise (typ. pp)		
Q <900 pC	pC	<0,6
Q <31k pC	pC	<21
Q <1M pC	pC	<720

Data acquisition

Resolution (delta-sigma)	bits	24
Sampling rate	ksps	105
Group delay for signal conditioning (plus group delay for low-pass filter)	µs	160
4th order low-pass filter (type: Bessel) Cutoff frequency (-3 dB)	Hz	1...20 000 in stages 1/2/5/10 per decade filter off = 20 000
Group delay (complete system) low-pass (LP)		
LP= off (20 000 Hz)	ms	<0
LP= 10 000 Hz	ms	<0,023
LP= 5 000 Hz	ms	<0,057
LP= 2 000 Hz	ms	<0,158
LP= 1 000 Hz	ms	<0,327
LP= 500 Hz	ms	<0,663
LP= 200 Hz	ms	<1,67
LP= 100 Hz	ms	<3,36
LP= 50 Hz	ms	<7,62
LP= 20 Hz	ms	<17,7
LP= 10 Hz	ms	<34,6
LP= 5 Hz	ms	<68,2
LP= 2 Hz	ms	<169
LP= 1 Hz	ms	<337

General data

Operating temperature range	°C	-20 ... 65
Storage temperature	°C	-40 ... 85
Vibration resistance IEC60068 Part 2-6 (58 ...150 Hz constant)	gp	1
Shock resistance IEC60068 Part 2-27 (11 ms)	g	200
Degree of protection as per EN60529 (only with cables fitted and/or covered connectors)	IP	67
Housing material		Die-cast aluminum
Weight	g	420
Installation position		As desired

Power supply

Supply voltage	VDC	18 ... 30
Power consumption at 24 V	mA	<200
Output current for cascading at 24 V, at dt +10 °C	A	<1,5
Overvoltage resistance, 40 ms/max	V	55
Electrical isolation against measuring circuit and digital inputs typ. (not safety-relevant)	VDC	<50

Industrial Ethernet communication

Hardware	Standard Ethernet IEEE 802.3 100 Base-Tx
	Transformer-coupled

Profinet IO

Slave as per		PNO standards
Provision for supported protocols for		RT, IRT
Minimum update rate	µs	250

EtherCAT

Slave as per		ETG standards
Provision for supported protocols for		CoE, DC
Minimum update rate	µs	100

EtherNet/IP

Slave as per		ODVA standards
Provision for supported protocols for		CIP
Minimum update rate	µs	1 000





5074A_003-332e-09-17

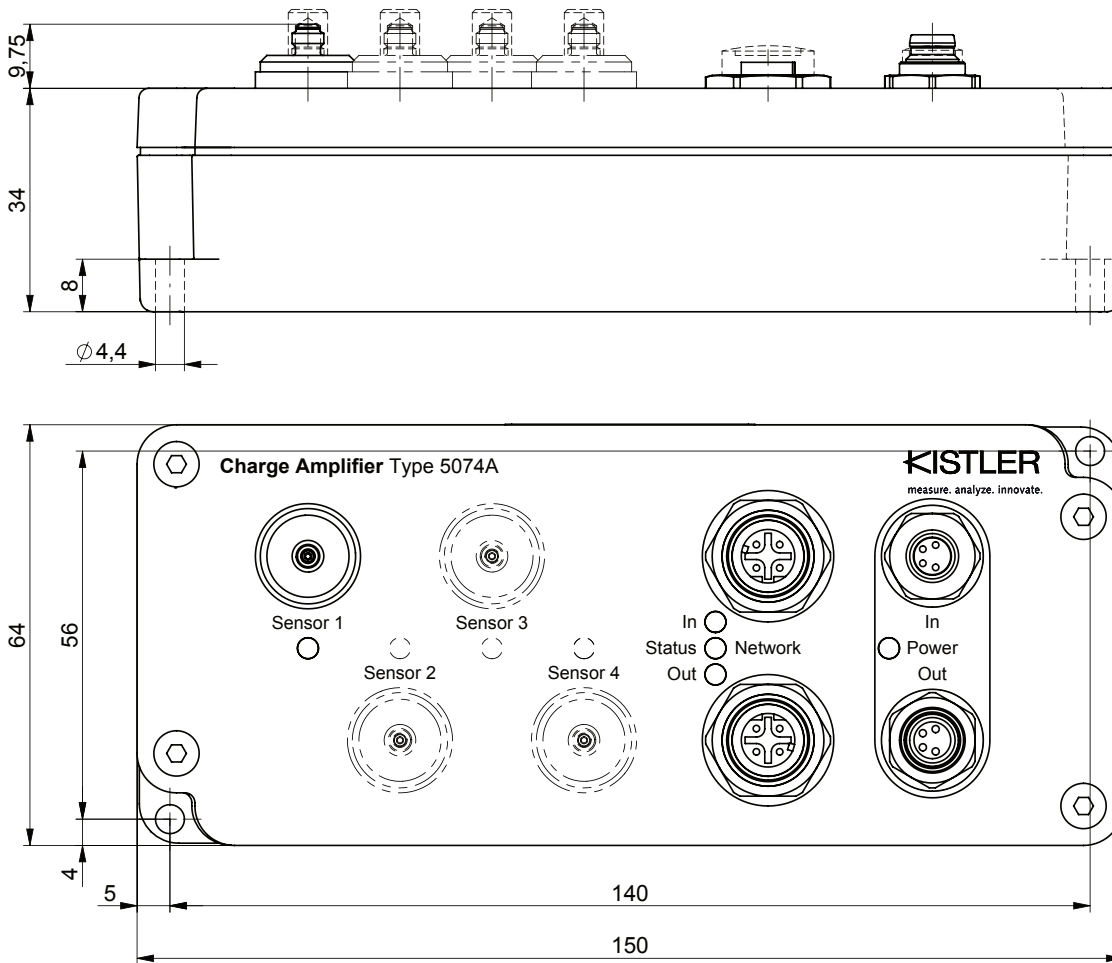



Installation

The device is installed with two M4 hexagon socket head cap screws



Blink codes

Sensor LEDs per channel	
Initialization	Flashing yellow 
Reset	Flashing blue 5 Hz 
Operate	Blue 
Overload	Red 

Network LEDs	EtherCAT	PROFINET
In/out: link	-	Yellow 
In/out: activity	Flashing yellow	Flashing green 
Status: init / error	Flashing green	Green 
Status: normal	off	off 

5074A_003-332e-09.17

Connections

Sensor charge input	Type	KIAG 10-32 UNF neg.
Energy supply	Type	M8 4-pole pos. A-coded

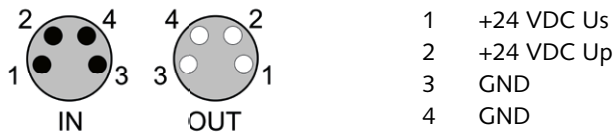

Industrial Ethernet connection	Type	M12 4-pole neg. D-coded
--------------------------------	------	-------------------------

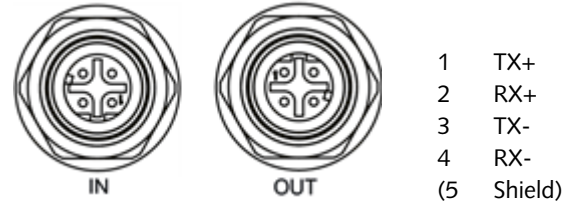

Ordering key

Charge amplifier

Inputs

1-channel charge	1
2-channel charge	2
3-channel charge	3
4-channel charge	4

Sensor connection socket

KIAG 10-32 UNF neg. – IP67	1
----------------------------	---

Industrial Ethernet type

EtherCat	1
EtherNet/IP	2
ProfiNet	3

Typ 5074A



Example of order

- 1-channel, KIAG 10-32 UNF neg., EtherCAT: 5074A111

Included accessories

- Protective cap IP54 for sensor input **Type** 1891
- Protective cap for M12 socket **Type** 55160137
- Protective cap for M8 socket **Type** 55137563

Optional accessories

- Sensor cable, PFA, IP65 **Type** 1635Cxxx
Connector, KIAG 10-32 UNF pos.
Connector KIAG 10-32 UNF pos.
- Sensor cable extension, PFA, IP65 **Type** 1637Cxxx
Socket, KIAG 10-32 UNF neg.
Connector, KIAG 10-32 UNF pos.
- Sensor cable with metal braiding PFA, IP65 **Type** 1657Axxx
Connector, KIAG 10-32 UNF pos.
Connector, KIAG 10-32 UNF pos.
- Protective cap with O-ring, IP67 for sensor connection **Type** 55145253
- Network cable, **Type** 1200A195A2
Connector, RJ45,
Connector, M12 pos. 4-pole D-coded,
length 2m
- Network cable, **Type** 1200A195B0,2
Connector, M12 pos. 4-pole D-coded,
Connector, M12 pos. 4-pole D-coded,
length 0.2 m
- Power cable, **Type** 1200A239A2
Socket M8 neg. 4-pole A-coded
Free end, length 2m
- Power cable, **Type** 1200A239B0,2
Connector, M8 pos. 4-pole A-coded
Socket M8 neg. 4-pole A-coded,
length 0.2 m

Industrial Ethernet details

Communication principle:

The device is configured individually for each channel, and the startup parameters are stored in the control. A configuration change can also be sent to the device via acyclical data during the measurement, but this change only becomes active after a Reset cycle.

The cyclical output data block contains the control bits for each channel. The control bits are applied to the internal status machine and, after execution, are mirrored in the status bits which are sent to the control via the cyclical input data block.

1. Start the measurement by setting the 'Operate' and 'Peak control' control bits (confirmed with status bits)
2. Reset unwanted peak values by briefly changing the status of the 'Peak control' control bit
3. Peak values retain the detected min./max. values while measurement is ongoing. (Acquisition is at maximum internal sampling rate, with or without applied filter)
4. End the measurement by deleting the 'Operate' and 'Peak control' control bits

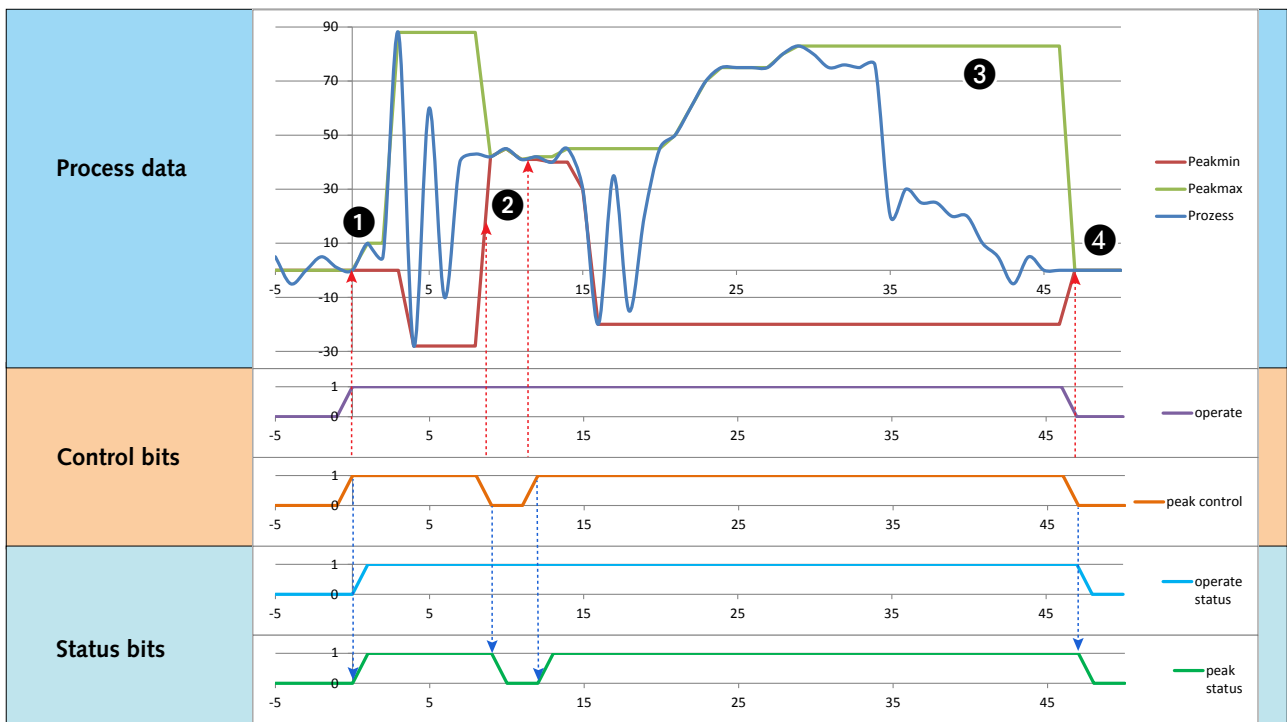

Figure 1: Control and time response

User parameters (cyclical):

Input data channel 1	Input data channel 2	Input data channel 3	Input data channel 4
Output data channel 1	Output data channel 2	Output data channel 3	Output data channel 4

5074A_003-332e-09-17

Structure of output data block

Name	Data type	Length (bytes)	Description
Control	Bit field	1	
0. Operate			0 = Reset, 1 = Operate, measure
1. Peak control			0 = Reset peak capture, 1 = Peak acquisition active
2. Integral control			0 = Reset integral, 1 = Integral active

Structure of input data block

Name	Data type	Length (bytes)	Description
Status Ch(n)	Bit field	1	
0. Operate state			Bits 0...2: status bits follow the control bits and signal successful execution of the requested function. For example, 'Operate state' clears when the channel reset is completed after the 'Operate' control bit was set to 0.
1. Peak control state			
2. Integral control state			
3. Parameter active			Changes to 0 when parameters are changed due to acyclical communication during measurement. The bit remains at 0 until the next Reset state, which activates the new parameters.
4. Reserved			Reserved
5. Overload			Indicates that the set measurement range was exceeded, and remains active until the next Reset cycle. Extreme overload with violation of hardware limit also sets the error bit until the next Reset cycle.
6. Warning			According to the table of error codes
7. Error			According to the table of error codes
Instant value Ch(n)	REAL	4	Measurement values scaled with divisor
Peak min ch(n)	REAL	4	Captured with max. internal sampling rate, filtered or unfiltered
Peak max ch(n)	REAL	4	Captured with max. internal sampling rate, filtered or unfiltered
Integral ch(n)	REAL	4	Integral value
Ch(n) int sample (1...of)	INTEGER	2 x oversampling factor	Scaled measurement values standardised with measurement range to 16-bit

(n)= channel number
(of) = oversampling factor

5074A_003-332e-09.17

User parameters (acyclical)

The following structure shows the parameter list for one measuring channel.
This structure is repeated for each additional measuring channel. (n = channel number 1...4)

Parameter name	Parameter type	Length (bytes)	Default	PROFINET index	EtherCAT object
Scaling divisor	FLOAT (pC/phys. unit)	4	1.0	0x2002	0x50n0:02
Range	FLOAT (physical unit)	4	1 000 000	0x2001	0x50n0:01
Filter frequency	Enum - no filter (20 kHz) (0) - 10 000 Hz (1) - 5 000 Hz (2) - 2 000 Hz (3) - 1 000 Hz (4) - 500 Hz (5) - 200 Hz (6) - 100 Hz (7) - 50 Hz (8) - 20 Hz (9) - 10 Hz (10) - 5 Hz (11) - 2 Hz (12) - 1 Hz (13)	1	0	0x2003	0x50n0:03
Time constant	Enum - off (0) - active (1)	1	0	0x2004	0x50n0:04
Peak mode	Enum - filter off (0) - filter active (1)	1	0	0x2005	0x50n0:05
Error code	2 byte	2	Read-only	0x2010	0x51n0:01

Byte #	Bit # Error code	Name	Description	Class	Possible cause
0	0	Reset warning	Charge amplifier's Operate-Reset time was violated	Warning	- The reset time for the charge input was too short; note the status bits.
	1	Sync warning	The sampling rate exceeds the internal processing capacity	Warning	- Communication cycle is too short - Too much measurement data - Fault due to acyclical commands
	2	Temperature warning	Internal CPU temperature is too high	Warning	- Ambient temperature is too high
	3				
	4				
	5				
	6				
	7				

5074A_003-332e-09:17

Byte #	Bit # Error code	Name	Description	Class	Possible cause
1	8	Hardware over-load	Charge amplifier module overload	Error	- The input signal has exceeded the hardware range
	9	Parameter out of range	The combination of scaling factor and measurement range exceeds the technically possible range	Error	- Physical measurement range in pC is exceeded with the specified parameters
	10	Calibration data error	No calibration data available	Error	- Device has lost calibration - Device was not calibrated correctly - Device identification is incomplete
	11	Hardware error	Peripheral error	Error	- No ADC values - No FPGA data
	12	Channel data error	Channel not available on device	Error	- The channel addressed is not available on this device
	13				
	14				
	15				

Performance table

The attainable cycle times depend on operating mode and process data.
Maximum sampling rate attainable without field bus synchronization option: 4kHz

Sync shift time for EtherCAT [µs]				
Measurement values	1 channel	2 channels	3 channels	4 channels
Cyclical data: - Status - Instant value - Peak minimum - Peak maximum - Integral	80	90	100	110

Table 1: Influence of process data types on sync shift time

Maximum attainable field bus cycle time [µs]				
Oversampling factor	1 channel	2 channels	3 channels	4 channels
1	100	100	100	100
2	125	125	125	125
4	125	125	125	200
5	125	125	200	200
8	200	200	200	200
10	200	200	200	250
15	333	333	333	333
20	500	500	500	500
25	500	500	500	500
50	1 000	1 000	1 000	1 000

Table 2: Relationship between synchronized oversampling data and attainable cycle times

5074A_003-332e-09:17

Block diagram

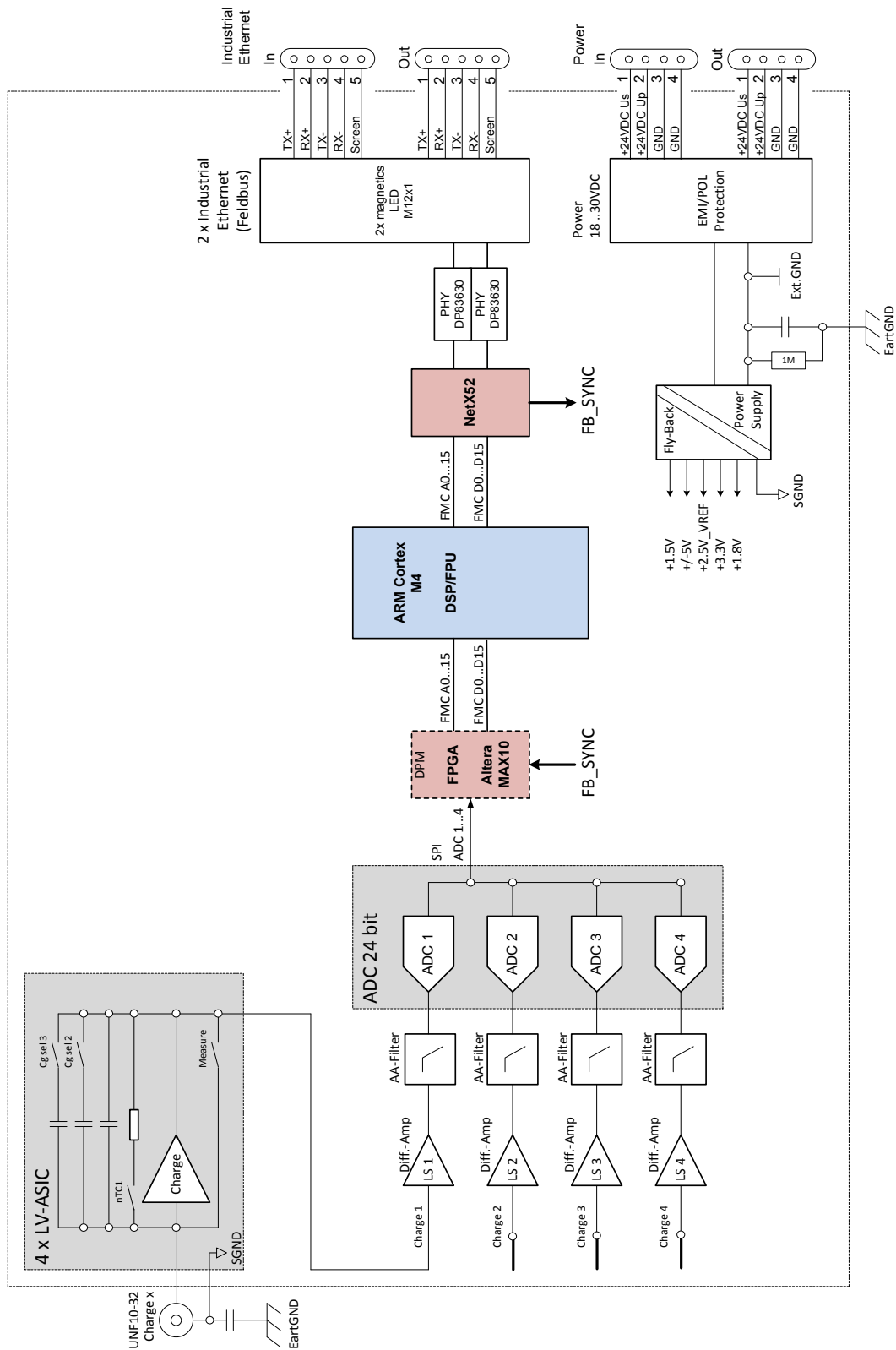

5074A_003-332e-09.17