

BOOSTER



CHEM



EXTRU



PURO



POLY



CHEM

High precision gear pump
for the chemical industry



CHEM

CHEM gear pump for conveying and metering of fluids with low to medium viscosity. The application range goes from classic transfer and metering tasks in the chemical and pharmaceutical industries up to the conveyance of monomers, oligomers and prepolymers during the polymerization process.

Decades of experience in design and an optimum selection of materials, make this type of pump suitable for even the most demanding tasks and are outstanding in their reliability and metering precision in both vacuum and high pressure applications. Typical areas of application for this type of pump are to be found in the chemical, cosmetic, food, petrochemical and polymer industries. The CHEM series is also suitable for the food industry, e.g. for conveying butter, margarine or vegetable oils. Pumps of this type can be supplied with or without heating. The WITTE modular construction system for bearings, gears and shaft seals offers a maximum of flexibility for the end customer.



Technical Features

Housing:	Stainless steels, carbon steels, tantalum, titanium, Hastelloy®, ceramics
Gears:	1.4112 (440B) but also all other processable ceramics and metals, e.g. 1.4571 (316Ti), Ferralium®, Ferro Titanite®, Hastelloy®, etc., optional: surface coating, spur gearing
Friction Bearings:	Carbon, NiAg (nickel-silver), silicon carbide (SiC), zirconium oxide, tool steel, Al-bronze, special materials, optional: surface coating
Shaft Seals:	Internal single mechanical seal (ED), External single mechanical seal with buffer fluid (AD), Double mechanical seal with buffer fluid (DD), Magnetic coupling, stuffing box, viscoseal and combinations
Heating Systems:	Steam, water, heat transfer oil, electrical

Operating Parameters

Viscosity:	0,5 to 1.000.000 mPas
Temperature:	Up to 300 °C (580 °F), higher temperatures upon request
Suction Pressure:	Vacuum to max. 15 bar (218 psig), higher with magnetic drive
Differential Pressure:	Up to 120 bar (1.740 psig)

The values listed are maximum values and must not coincide under certain circumstances.

Seals

Pump Sizes

From 22/6 (1,28 cm³/rev) up to 280/280 (12.000 cm³/rev).

Sizes with longer gears for all types available e.g. 140/210 (2.223 cm³/rev).

Application Examples

Organic and Inorganic Chemicals:

Alcohols, additives, bases, esters, glycerine, resins, hardeners, isocyanates, monomers, oils, phenol, acids, biodiesel, asphalt, bitumen, tar, hotmelt, glues, waxes, etc.

Polymers:

Celluloseacetate, Nylon 66[®], prepolymers, etc.

Food:

Edible oils, butter, margarine, flavourings, chocolate, fudge, liquorice, chewing gum, vitamins, syrup, gelatine. etc.

Pharmaceutical and Cosmetic Products:

Amino acids, lotions, shampoo, vitamins etc.

Mechanical Seals

Single mechanical seal (ED)



Suction Pressure:

Up to 15 bar
(abs) (218 psig)

Viscosity:

0,5 - 50.000 mPas (cP)

Temperature:

max. 300 °C (580 °F)

Double mechanical seal with buffer fluid (DD)

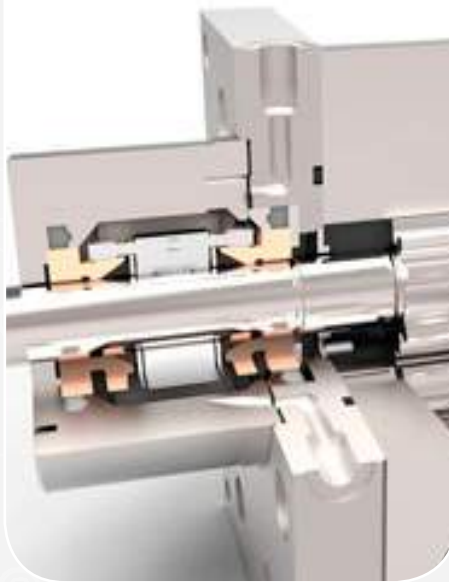

Suction Pressure:

Vacuum to max. 15 bar
(abs) (218 psig)

Viscosity:

0,5 - 1.000.000 mPas (cP)

Temperature:

max. 300 °C (580 °F)

Single mechanical seal with buffer fluid (AD)



Suction Pressure:

Vacuum to max.
atmosph. pressure (abs)

Viscosity:

0,5 - 100.000 mPas (cP)

Temperature:

max. 200 °C (392 °F)

CHEM MAGNET

The CHEM MAGNET is in general designed in the same way as the CHEM but it is supplied with a synchronous magnetic coupling as shaft seal. This operates slip-free, i.e. the pump speed is always the same as the drive speed.



The magnetic coupling lends itself to conveying poisonous or flammable substances, as well as for operation at high system pressures. Special versions can be used for inlet pressures of up to 500 bar (7.252 psig).

The containment shell of the magnetic coupling can be double-walled type. The double wall serves heating the coupling can. The double-walled containment shell can be provided with a leakage-monitoring system for particularly critical processes. The containment shell is filled with inert gas, in order to detect damage. If this gas escapes to the inside or outside, depending upon which wall is damaged, a pressure sensor will trigger an alarm. Because one wall of the double-walled containment shell is still intact, the possibility of the hazardous medium being conveyed leaking into the environment will be eliminated.

A particular highlight of the WITTE Magnetic Coupling is the inner magnetic rotor's separate bearing. This ensures that only torque is transferred to the pump's drive shaft. The relatively heavy weight of the inner rotor is taken up by this bearing, thus relieving the pump's bearings.

WITTE's flange bearing design offers the additional advantage of preventing the inner rotor from touching and damaging the containment shell. In competitors design it is possible for the inner rotor to touch the containment shell after pump bearings wear. Our design provides the safety of an additional bearing to insure the inner rotor can not touch the containment shell.



Operating Parameters

Viscosity:	0,5 to 30.000 mPas (cP)
Temperature:	Up to 350 °C (662 °F)
Suction Pressure:	Vacuum to max. 500 bar (7.252 psig)
Differential Pressure:	Up to 120 bar (1.740 psig)

Pump Sizes

From 22/6 (1,28 cm³/rev) to 180/180 (3.200 cm³/rev).

The values listed are maximum values and must not coincide under certain circumstances.

Technical Features

Housing:	Stainless steel, tantalum, titanium, Hastelloy [®] , ceramic
Gears:	1.4112 (440B) but also all other processable ceramics and metals, e.g. 1.4571 (316Ti), Ferralium [®] , Ferro Titanite [®] , Hastelloy [®] etc., optional: surface coating, spur gearing
Friction Bearings:	Carbon, NiAg (nickel-silver), silicon carbide (SiC), zirconium oxide, tool steel, Al-bronze, special materials, with optional surface coating
Heating Systems:	Water, heat transfer oil

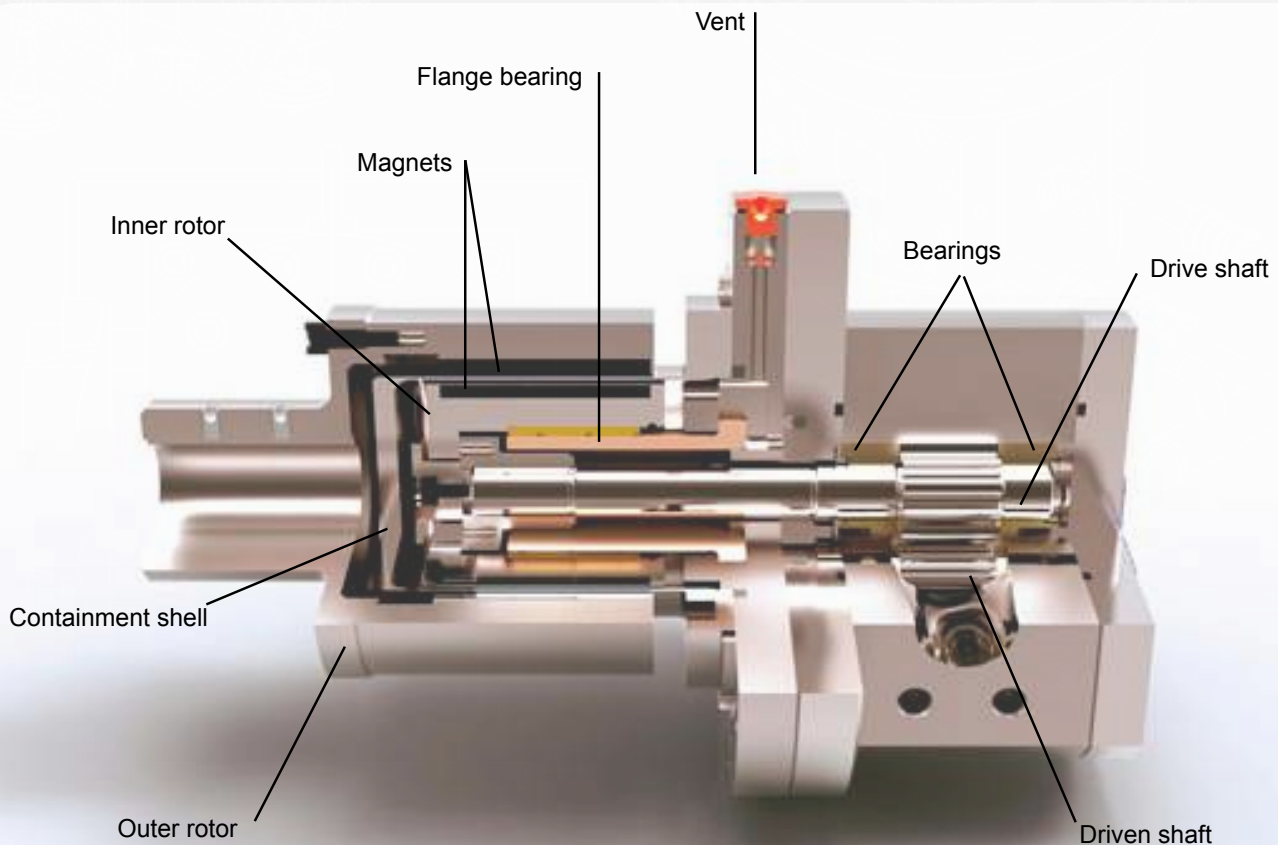

Metering Systems / Special Pumps

Metering System

The WITTE metering system (WDS) enables precise volumetric metering of low to high viscosity media with gear pumps, even at high temperatures and pressures. Two series connected gear pumps, one measuring and one pressure boosting pump are precisely controlled by a PLC control system, such that a precision of better than 0.1% is achieved, depending upon the medium.



Special Pumps

In addition to our standard pumps, we offer a wide range of special pumps, e.g. made of ceramic, tantalum, titanium or immersion pumps. Many of these pumps are custom built to suit the application in question and its specific operating parameters. WITTE for example produced one such pump, made completely of ceramic, for transporting a highly corrosive medium at temperature 550° C.



Special pumps examples



Size / Displacement Volume / Capacity

Pump Sizes

Size	Spec. displacement volume (cm ³ /rev)	Capacity (l/h)*
1/1 (22/6)	1,28	20 - 200
1/2 (22/13)	2,78	40 - 400
1 (22/22)	4,7	70 - 700
2 (28/28)	10,2	140 - 1400
3 (36/36)	25,6	280 - 2800
4 (45/45)	46,3	410 - 4100
5 (56/56)	92,6	650 - 6500
6 (70/70)	176	990 - 9900
7 (90/90)	371	1600 - 16200
8 (110/110)	716	2500 - 25300
9 (140/140)	1.342	3800 - 37800
10 (180/180)	3.200	6900 - 69100
11 (224/224)	6.100	11000 - 106000
12 (280/280)	12.000	17000 - 170000

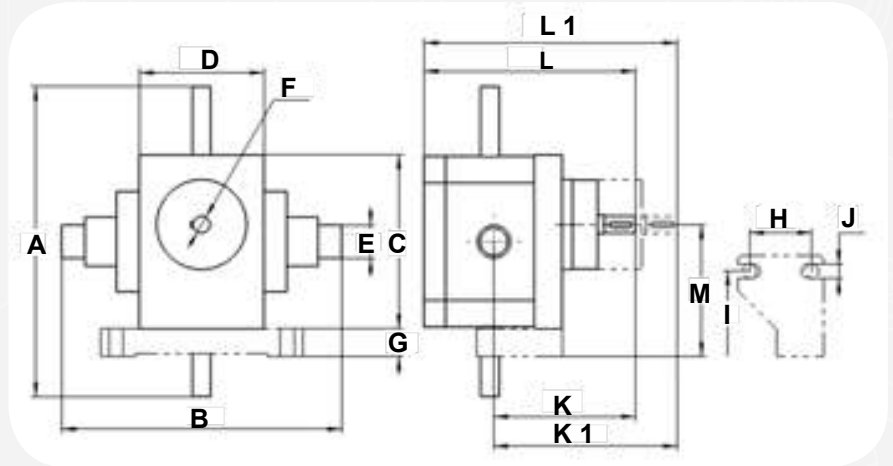

* (Depending on the fluid characteristics and operating conditions)

CHEM Dimensions

Size	A	B	C	D	E Ø	F Ø	G	H	I	J	K	K1	L	L1	M	Weight
1/1 (22/6)	200	116	112	80	20/15	11	18	40	110	9	83	110	120	147	85	6 Kg
1/2 (22/13)	200	116	112	80	20/15	11	18	40	110	9	86.5	113.5	127	154	85	6 Kg
1 (22/22)	200	180	112	80	21.3	11	18	40	110	9	91	118	136	163	85	6 Kg
2 (28/28)	235	208	138	108	33.7	16	22	40	130	11	109	138	160	189	105	15 Kg
3 (36/36)	250	214	152	114	48.3	19	16	60	140	12	124	157	188	221	110	20 Kg
4 (45/45)	234	244	176	134	60.3	24	25	75	170	14	148	186	226	265	135.5	26 Kg
5 (56/56)	360	264	210	168	60.3	32	27	100	220	20	195.5	239.5	289.5	333.5	160	50 Kg
6 (70/70)	350	346	258	208	76.1	38	27	115	250	22	225.5	275.5	338.5	388.5	191	125 Kg
7 (90/90)	498	416	300	269	88,9	48	42	130	310	28	265	329	405	469	237	220 Kg
8 (110/110)	470	488	380	310	114,3	60	42	180	410	28	319	478	384	543	287	340 Kg
9 (140/140)	600	538	454	340	168,3	70	47	230	430	28	410	457	612	669	344	500 Kg
10 (180/180)	800	*1	590	440	219,1	*2	65	285	520	33	617	617	902	902	450	700 Kg

*1 Upon Request

*2 W100 x 2,5 x 38 / DIN 5480

Operating Conditions

CHEM

Transfer
Metering
Pressure increase
Thin film evaporation

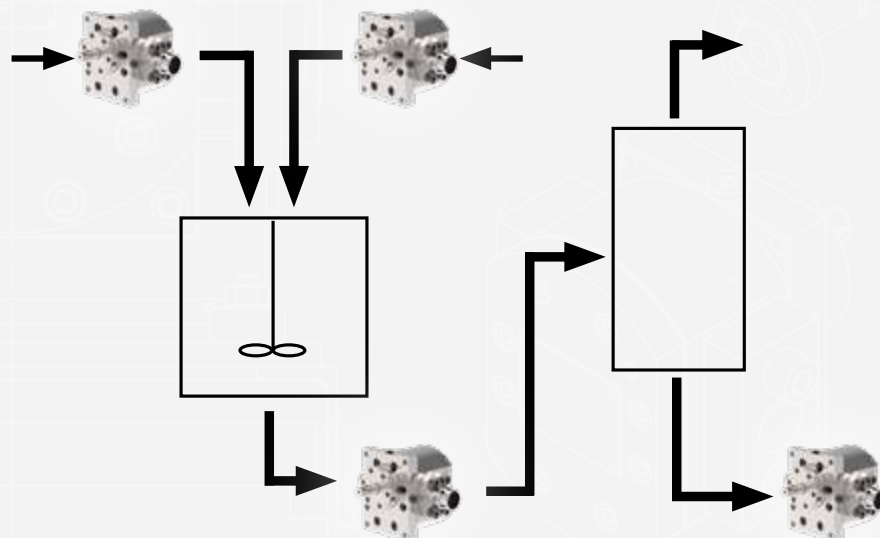

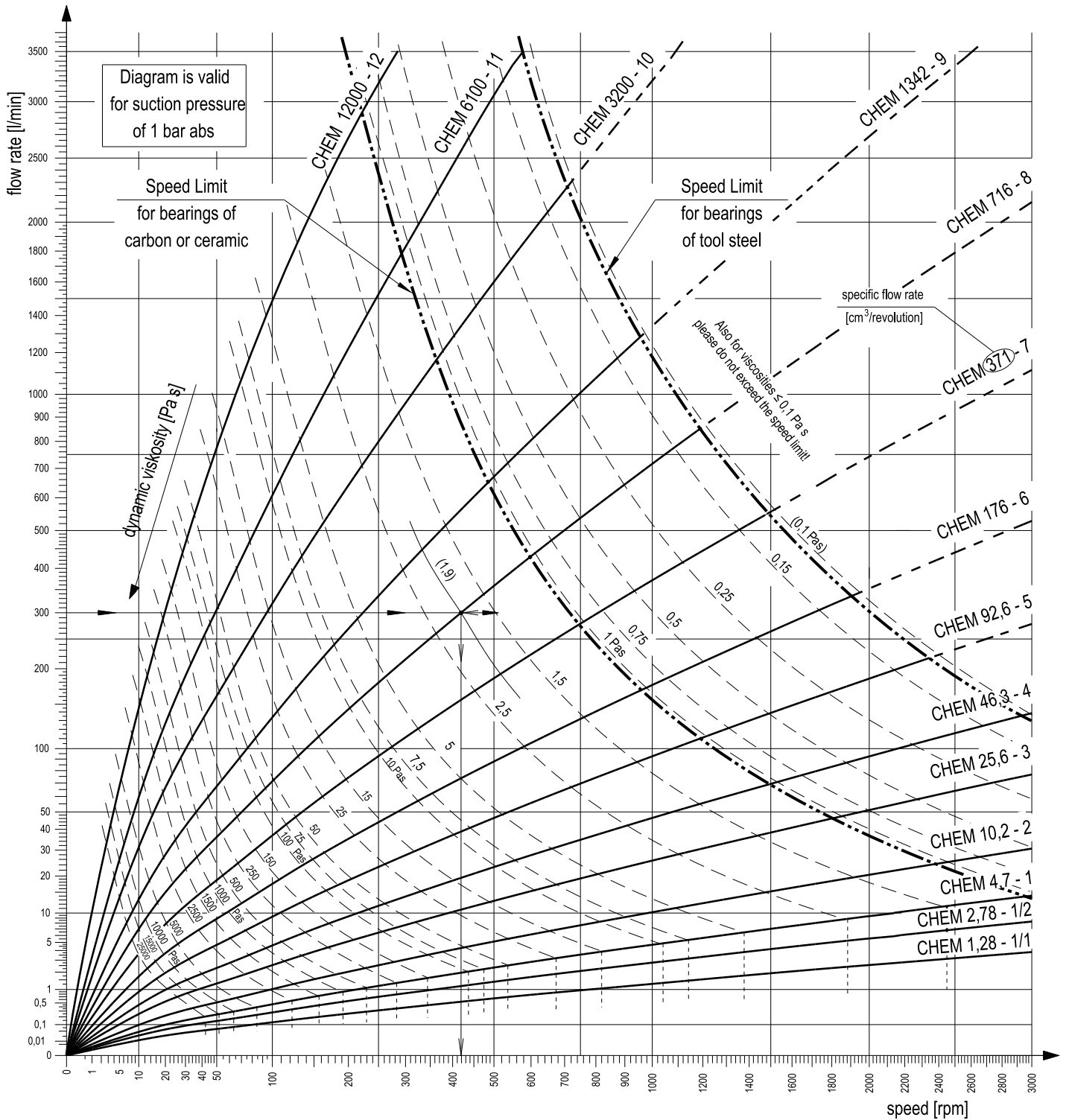

WITTE PUMPS & TECHNOLOGY GmbH
 Lise-Meitner-Allee 20
 D-25436 Tornesch / Hamburg / Germany

P: +49 (0) 4120 70659-0
 F: +49 (0) 4120 70659-49
 info@witte-pumps.com
 www.witte-pumps.com

