



Instruction manual

TU 8325 - TU 8525

TURBIDITY PROBE

4-20 mA - RS485 - Modbus RTU

Scales

0.000 ÷ 4.000 NTU

0.00 ÷ 40.00 NTU

0.0 ÷ 400.0 NTU

Option

S/N

REP N°

Power supply: 9 ÷ 36 Vdc

Installed firmware: R 3.0x

Valid also for models:

TU8525.5



TU 8325



TU 8525

INDEX

1 - GENERAL WARNINGS AND INFORMATION FOR ALL USERS	3
1.1 Warranty	3
1.2 After sales service	3
1.3 CE marking	3
1.4 Safety warnings	3
1.5 Special warnings	4
1.6 Manual revisions	4
2 - PRODUCT OVERVIEW	5
2.1 Functional purpose of the device	5
2.2 Accessories	6
3 - INSTRUCTION MANUAL CONTENTS	7
3.1 Symbols	7
3.2 How to read the instruction manual	7
4 - SPECIFICATIONS AND TECHNICAL DATA	8
4.1 Functional specification	8
4.2 Technical data	10
4.2.1 General specifications	10
4.2.2 Technical specifications	11
5 - INSTALLATION	14
5.1 Packing list	14
5.2 Unpacking and repacking of the unit	14
5.3 Storage and transport	14
5.4 Installation of TU 8325	14
5.5 Installation of TU 8525	15
5.6 Electrical installation	16
5.6.1 Connection in analog mode to B&C instruments	16
5.6.2 Network connection (RS485)	17
5.6.3 Connection in digital mode to B&C instruments	18
5.7 Disposal	18
6 - OPERATING PROCEDURE	19
6.1 Operating principle	19
6.2 Operating mode	19
6.3 Analog mode	19
6.4 Digital mode	20

6.4.1	B&C communication protocol	21
6.4.2	Modbus protocol	35
7 - MAINTENANCE		43
<hr/>		
7.1	Calibration	43
8 - INSTALLATION DRAWINGS		45
<hr/>		
8.1	TU 8325 - Dimensions	45
8.2	TU 8325 - Typical installation	46
8.3	TU 8525 - Dimensions	47
8.4	Analog mode wiring	48
8.5	Digital mode wiring	49
9 - WARRANTY		50
<hr/>		
10 - REPAIRS		50
<hr/>		

1 GENERAL WARNINGS AND INFORMATION FOR ALL USERS

1.1 WARRANTY

This product is guaranteed for 5 years from the date of purchase for all manufacturing defects.

Please take a look at the terms and conditions described on the warranty certificate at the end of the manual.

1.2 AFTER SALES SERVICE

B&C Electronics offers to all of its customers the following services:

- a free of charge technical assistance over the phone and email for problems regarding installation, calibration and regular maintenance;
- a repairing service in our Carnate (Italy) headquarter for all types of damages, calibration or for a scheduled maintenance.

Please take a look at the technical support data sheet at the end of the manual for more details.

1.3 CE MARKING

This instrument is manufactured according to the following european community directives:

- 2011/65/EU "Restriction of the use of certain hazardous substances in electrical and electronic equipment"
- 2014/30/EU "Electromagnetic compatibility" EMC

- EN 61326-2-3/2013 "Electromagnetic compatibility" EMC
 - Industrial electromagnetic environment
- EN 55011/2009 "Radio-frequency disturbance characteristics"
 - Class A (devices for usage in all establishment other than domestic)
 - Group 1 (Industrial equipment that do not exceed 9kHz)

The **CE** marking is placed on the packaging and on the S/N label of the instrument.

1.4 SAFETY WARNINGS

It is important to underline the fact that electronic instruments are subject to accidental failure. For this, it is important to take all necessary precautions to avoid damages caused by malfunctions.

Any operation must be performed by authorized and trained staff.

The use must comply with the parameters described in chapter "Specifications and technical data (page 8)", in order to avoid potential damages and a reduction of its operating life.

1.5 SPECIAL WARNINGS

In order to ensure a reliable operation and to prevent irreversible damage, it is important to avoid all of the following:

- prolonged exposure to direct sunlight;
- cleaning too frequently and excessive air pressure;
- leaving the compressed air input device open if not used;
- unscrewing or loosening the cable gland or the probe body.

1.6 MANUAL REVISIONS

This chapter shortly describes the differences between previously released versions of the same manual, so to help users that are already familiar with the product.

Rev. C	Modbus RTU function 06 and 16 ID+SN commands Bootloader function
Rev. B	New layout Scalable output Filter software Modbus protocol
Rev. A	Emission

2 PRODUCT OVERVIEW

2.1 FUNCTIONAL PURPOSE OF THE DEVICE

This probe has been designed to measure low turbidity values according to the nephelometric method (ISO 7027 - EN 27027).

Applications

The main applications include drinking water, civil and industrial treatment and water quality monitoring.

Models

TU 8325 for submersible applications, provided with an autoclean nozzle for external pressured air.

TU 8525 for in flow application into flow cell or in pipe.

TU 8525.5 for in flow application into flow cell or in pipe, PVDF body.

Probe composition

The measuring system consists of:

- infrared light source;
- 90 degree scattered light detector;
- clean lens status detector;
- temperature sensor;
- built-in 2-wire 4-20 mA transmitter;
- RS 485 output with B&C protocol for data transmission, calibration and configuration procedures.

The probe can operate in analog or digital mode (see chapter "Operating procedure (page 19)").

The TU 8325 probe is equipped with a device for automatic cleaning consisting of a conduit and by an injector which directs a jet of compressed air on the sensitive part, keeping it clean from incrustations and deposits of organic substances.

The probe can work connected as a slave to the MC 6587 and MC 7687 instruments that function as master.

2.2 ACCESSORIES

Sensors and accessories for different applications are available, to be ordered separately.

Our staff is always available to help costumers select the most appropriate and suitable solution for their specific needs.

Accessories



BC 8701 RS485/USB converter with Vdc output

Accessories for TU 8325



0012.450043 adapter for extension pipe



0012.000624 swivel mounting for extension pipe (0012.450043 is included)

0012.440040 PVC tubing for pressure air, L = 33 m

Accessories for TU 8525



TU 910 flow cell

TU 920 flow cell



1892702 adapter for installation in pipe

2713118 O ring for 1892702

SZ 7521 adapter for extension pipe



TU 9632 Dry turbidity simulator

3 INSTRUCTION MANUAL CONTENTS

This chapter describes the manual and gives suggestions to all users on how to read it and use it.

The manual is written according to the following norms:

- UNI 10893 "Instructions for use";
- UNI 10653 "Quality of product technical documentation".

The terminologies indicated in the international metrology vocabulary (VIM) are respected as far as possible.

3.1 SYMBOLS

Throughout the manual you may find the following symbols, which are both dictated by a norm or that are simply conventional.



WARNINGS: this symbol is used to warn users that if the instructions are ignored or not correctly followed, damage to the instrument can be caused.



NOTE: *this symbol is to invite the user to pay particular attention to a specific section of the manual.*

3.2 HOW TO READ THE INSTRUCTION MANUAL

The manual contains all the information needed to acquire full knowledge of the product, to ensure a proper installation, proper use and maintenance in order to achieve the desired result at the time of its choice.

The manual is aimed at staff with appropriate knowledge and experience in the field of measurement and control through the use of sensors and transmitters in the context of industrial plants.

The index of the manual refers the reader to the chapters on aspects that want to learn and develop.

In particular, the first chapters show general topics and allow the user to become familiar with the product, with its functional purpose and with the necessary accessories or options for its use.

The user can then check whether he knows all the elements necessary for the use of the instrument and of the measuring/control.

4 SPECIFICATIONS AND TECHNICAL DATA

4.1 FUNCTIONAL SPECIFICATION

Inputs

The probe is able to perform the measurement of turbidity and temperature.

Scale

The instrument allows the selection of three different scales: 4.000 / 40.00 / 400.0 NTU.

For all it is possible to set the scalability factor to obtain different full scale values on the analogue output.

Check signal

The probe is capable of detecting problems that alter the measure, such as dirt on the optical windows, lack of contact with liquid and external light too high.

The fault condition is signaled by an alarm on the analog output and an error flag on the record transmitted through the digital output.

Analog output

The probe operates in current loop 4-20 mA proportional to the value of the principal measure.

The output is galvanically isolated, so to be interfaced directly to a PLC, data acquisition cards or B&C Electronics instruments with 4-20 mA input.

Serial interface

Through the isolated RS485 interface, the user can connect the probe to a terminal or to a PC using a simple terminal emulation program. A RS485/RS232 or RS485/USB converter can be necessary.

Using B&C protocol, is possible measurements receiving, parameters setting and to calibration management.

Using Modbus protocol, functions 03, 06 and 16 are implemented for reading the measurements, changing the operating parameters and calibrating.

The MC 6587 and MC 7687 controllers from B&C Electronics allow complete management of the probe.

The bootloader function allows the firmware's update via serial port.

Filter software

The input signal has a filter with two selectable response time.

The user can separately set the response time relative to signals of small or large variation in order to obtain good reading stability and fast response to the variations of the measurement in the process.

In digital mode, the software filter acts only if the time interval between queries is significantly lower than the set filter time.

Power supply

The instrument is powered (min. 9 Vdc ÷ max. 36 Vdc) through the current loop, directly from a PLC or data acquisition boards that provide the power, or by a power supply in series between the analog output and the apparatus of acquisition.

When operating in digital mode the instrument is powered using the terminals of the current loop.

Configuration and calibration of the probe

Configuration and calibration of the probe are made via serial interface (see chapter "Digital mode (page 20)") or by using MC 6587 and MC 7687 controllers.

4.2 TECHNICAL DATA

4.2.1 GENERAL SPECIFICATIONS

Common specification

Cable	5 x 0.25 mmq, L= 10 m, sheath in PVC
Storage temperature	-5 °C ÷ +50 °C
Protection	IP68
Immunity performance loss	< 1 % full scale

TU 8325 specification

Operating temperature	-5 °C ÷ +50 °C
Operating pressure	0 ÷ 6 bar at 25°C 0 ÷ 3 bar at 50°C
Body	PVC
Diameter	60 mm
Length	165 mm
Thread	2"NPT
Autoclean	built-in nozzle
Air inlet fitting	1/4" internal, 3/8" external
Air pressure	3 bar max (for max 10 seconds)
Weight	body 420 g, cable 640 g

TU 8525 specification

Operating temperature	-5 °C ÷ +50 °C
Operating pressure	0 ÷ 6 bar at 25°C 0 ÷ 3 bar at 50°C
Body	PVC
Diameter	39.50 mm
Length	143 mm
Weight	body 160 g, cable 640 g

TU 8525.5 specification

Operating temperature	-5 °C ÷ +65 °C
Operating pressure	0 ÷ 10 bar at 25°C 0 ÷ 3 bar at 65°C
Body	PVDF
Diameter	39.50 mm
Length	143 mm
Weight	body 160 g, cable 640 g

4.2.2 TECHNICAL SPECIFICATIONS

MAIN MEASURING				Default
Measure		Turbidity		
Measuring method		Nephelometric		
Turbidity scales		4.000 / 40.00 / 400.0 NTU		400.0 NTU
Scale	Resolution	Under range	Over range	
0.000 ÷ 4.000 NTU	0.001 NTU	- 0.400	4.400	
0.00 ÷ 40.00 NTU	0.01 NTU	- 4.00	44.00	
0.0 ÷ 400.0 NTU	0.1 NTU	- 40.0	440.0	
Measuring cycle		2 seconds		
<u>Filter software</u>				
Response time at 90 % small signal		2 ÷ 220 seconds		120 s
Response time at 90 % large signal		2 ÷ 220 seconds		40 s
Zero		± 0.400 NTU on all scales		0.000 NTU
Sensitivity		70 ÷ 130 %		100 %
Zero standard solutions		0.000 ÷ 4.000 NTU		0.020 NTU
Sensitivity standard solutions		0.000 ÷ 400.0 NTU		400.0 NTU

SENSOR TYPE	Default
Turbidity sensor composed by:	
• Led	
• Photodiode for turbidity measuring	
• Photodiode for check signal	

CHECK SIGNAL	Default
Check signal scale	0.0 ÷ 200.0 %
Over range	220.0 %
Sensitivity	50.0 ÷ 200.0 %
Alarm from check signal and external light too high	On / Off
	Off

CHECK SIGNAL		Default
Min alarm (fouling or damaged led)	0.0 ÷ 100.0 %	10.0 %
Max alarm (dry cell)	100.0 ÷ 200.0 %	200.0 %
Alarm indications		
• Analog mode	every 16 s shows 3.8 / 21 mA	
• B&C protocol	see check error command A	
• Modbus protocol	see check error function 03	

TEMPERATURE		Default
Sensor for thermocompensation	RTD Pt100 (built-in)	
Compensation range	0.0 ÷ 50.0 °C	
Temperature comp. coefficient	internal table	

EXTERNAL LIGHT EVALUATION		Default
Scale	0.0 ÷ 100.0 %	
Alarm	On / Off	Off

CURRENT LOOP (DIGITAL MODE = 0)		Default
Current loop proportional to the measuring	4-20 mA	
Output scale factor	10 ÷ 100 %	100 %
Under / Over range	3.80 mA / 20.80 mA	
ID of the selected scale		
• Scale 4.000 NTU	8 mA at switching-on for 16 s	
• Scale 40.00 NTU	12 mA at switching-on for 16 s	
• Scale 400.0 NTU	20 mA at switching-on for 16 s	
Under alarm condition (if activated) of the check signal of:		
• dry cell;		
• fouling;		
• external light too high;		
the analog output will show the following sequence:		
• loop at 3.80 mA for 16 seconds;		

CURRENT LOOP (DIGITAL MODE = 0)		Default
• loop at 21.00 mA for 16 seconds.		
The above sequence is repeated during the alarm conditions.		
The analog output will restore automatically at the end of alarm conditions.		

DIGITAL FUNCTION		Default
Protocols	B&C protocol ASCII Modbus RTU The two protocols can coexist	
B&C ID protocol	ID = 01 ÷ 99 * last s/n digit, if 0 ID=10	01 ÷ 10 *
Modbus address	ID = 01 ÷ 243 * last s/n digit, if 0 ID=10	01 ÷ 10 *
Measures and parameters are provided under interrogation (see protocols B&C ASCII and Modbus RTU function 03 - 06 -16)		

SERIAL INTERFACE		Default
Interface	RS 485 not terminated	
	Isolated from the sample	
	Not isolated from the loop/power supply	
Baud rate	2400 / 4800 / 9600 / 19200 baud	9600 baud
Distance	1000 / 500 / 250 / 125 m	
Probes in network	32 probes max	

POWER SUPPLY		Default
Power supply	9/36 Vdc	
Absorptions		
• Digital mode = 0 • Digital mode = 1 • Digital mode = 2	Typical 4-20 mA, max 22 mA 8/12/20 mA according to the scale 7 mA	
	The absorption may be higher during transmission	

5 INSTALLATION

5.1 PACKING LIST

The instrument package contains:

- N° 1 turbidity probe;
- N° 1 instruction manual.

5.2 UNPACKING AND REPACKING OF THE UNIT

- 1 Open the carton box and keep it.
- 2 Remove the probe wrapped in clear plastic guard.
- 3 Remove the plastic cap.

 Handle the probe with care.

If repackaging do the reverse.

5.3 STORAGE AND TRANSPORT

For prolonged storage, keep the product in dry places.
In the case of transportation, pack the product in the carton box.

5.4 INSTALLATION OF TU 8325

Use with autoclean system

The probe should be submerged preferably with an inclination that favors cleaning air escaping upwards.

The swivel mounting 0012.000624 described in chapter "Accessories (page 6)" allows this type of installation.

Before the immersion of the probe it is necessary to make the following:

- provide an extension pipe with suitable length;
- provide the PVC tubing 0012.440040 with suitable length;
- prepare the 0012.450043 adapter;
- insert the flexible tubing in the air connector;
- insert the cable and the tubing in the adapter 0012.450043 and screw it on the probe;
- insert the extension pipe and screw it on the adapter.

 The pressure air provided by the customer must be a clean air at 3 bar max.

The typical cleaning time is 15 seconds and the typical cleaning frequency is 2 times/day, but it is depending of the application and the actual efficiency of the cleaning action.

Higher cleaning frequency could reduce the lifetime of optical lens, especially in the presence of abrasive suspended solids in the sample.

Use without autoclean system

Before the immersion of the probe, follow the above procedure but:

- do not install the flexible tubing;
- install a stopper on the air line connector in order to avoid the water entering into the room between the adapter and the probe when the probe is submersed.

 Without the stopper the water will damage the cable and it may leak inside the probe.

 The probe cable can be submerged but must check the compatibility of its PVC jacket with the sample liquid.

In any case it is necessary to periodically check that the cable is in good condition.

5.5 INSTALLATION OF TU 8525

This probe is designed for use online or in the flow cell TU 910 or TU 920 (refer to the latter's instructions for proper installation).

Is advisable to use the probe in the flow cell, especially in the case of measurements of turbidity up to 40 NTU.

- Insert the adapter with the O-ring on the probe;
- insert the probe into the flow cell;
- tighten the cell fixing ring nut.

In applications with high turbidity measures, the probe can also be installed directly in the flow, preferably in a bypass with shut-off valves in order to allow the removal of the probe for maintenance.

Contact our sales office for further clarification regarding this application.

The probe can also be installed in a tank with extension pipe adapter SZ 7521.

 Do not unscrew/remove the cable gland fitting. You can damage the internal circuits.

Warranty will not be applied if sensors are tampered with.

5.6 ELECTRICAL INSTALLATION

Connect the probe to the meter by following the color of the wires of the cable.

The operation mode via the current loop uses the white and green wires which are protected against reversed connection.

The shield of the cable is not connected inside the probe but must be connected to the system ground.

Wire colour	Function
Shield	not connected
Yellow	RS485 A (+)
Grey	RS485 B (-)
Brown	not connected
Green	+ current loop
White	- current loop / COM RS485



Do not connect the power supply on the RS485 interface wires (yellow and gray) to prevent breakage.

Avoid interruptions of the cable. If needed, use junction boxes with high insulation and the extension cable p/n 2423405 (5x0.25 - D 5.70 mm).

Keep the cable away from the power cables also inside the electrical panel.

5.6.1 CONNECTION IN ANALOG MODE TO B&C INSTRUMENTS

In analog mode is possible to connect the turbidity probe to instruments BC 7335 - BC 7635 - BC 7687 - BC 6587 of B&C Electronics in order to simplify their use by their characteristics listed below:

- configuration of the scale corresponding to 4-20 mA input signal;
- zero adjustment and sensitivity;
- two independent set points;
- alarm relay minimum / maximum;
- isolated output 0-20 mA or 4-20 mA;
- digital input to maintain the instrument in terms of hold during calibration or in the cycle of self cleaning.

Connect the sensor to the controller as follows:

Wire color	BC 7335	BC 7635	BC 7687	BC 6587
Green	20	20	20	25
White	22	22	22	23

Calibration

When the probe is connected to these controllers, you can calibrate the turbidity measurement using the zero/sensitivity adjustment available in the controllers and described in specific instruction manuals.

Working in this way avoids carry out the calibration of the probe by means of the digital connection that might be necessary only in case of degradation of the optical element.

5.6.2 NETWORK CONNECTION (RS485)

These digital probes use a RS485 driver with slow switching fronts.

This implies that it is not necessary to complete the termination of the transmission line even for long distances.

The following directions are to be considered as examples.

If the driver of the master device has very fast switching fronts, it may be necessary to terminate the beginning and end of the transmission line. In this case it should be inserted in the transmission line a pull-up and pull-down R_p resistors to keep the line polarized and to ensure the starting condition (start bit).

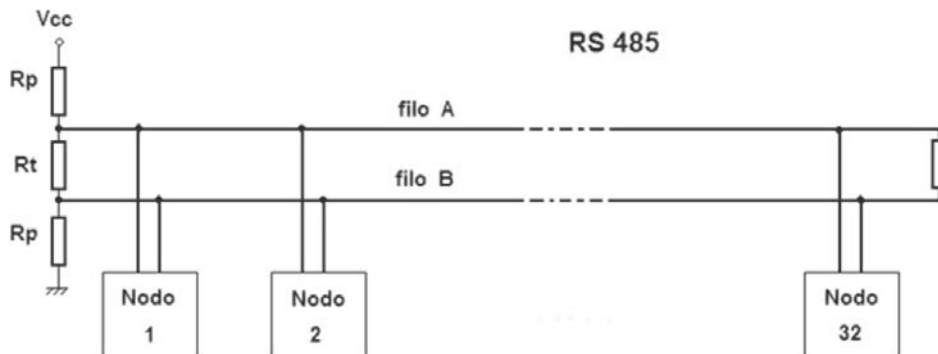

Fig. 1 Pull-up and pull-down resistors termination

If no power supply is available to insert the pull-up and pull-down resistances on the line, or to not overload the driver increasing the consumption of the sensors and devices, make an AC termination by inserting a capacitor in series with the terminating resistor.

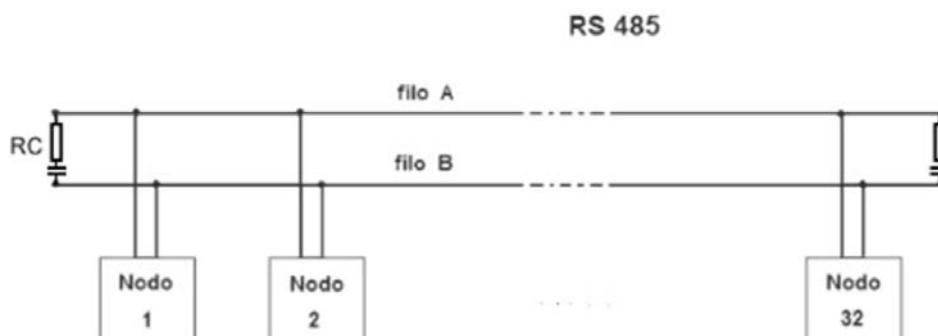

Fig. 2 AC termination

The capacitors to be used depend on the length of the cables and as an indication they are the following:

10 nF (150 m) - 22 nF (300 m) - 47 nF (600 m) - 100 nF (1200 m).

5.6.3 CONNECTION IN DIGITAL MODE TO B&C INSTRUMENTS

In digital mode is possible to connect the turbidity probe to instruments MC 7687 and MC 6587 of B&C Electronics.

For the available functions, refer to the instruments specific manuals.

Connect the sensor to the controller as follows:

Wire color	MC 7687	MC 6587
Green	40	35
White	37	32
Yellow	39	34
Grey	38	33

5.7 DISPOSAL

In the case of disposal of the instrument, apply the terms of the law provided for the disposal of electronic devices.

6 OPERATING PROCEDURE

6.1 OPERATING PRINCIPLE

The turbidity measurement is based on the ISO 7027 - EN 27027 standards.

A light beam is sent to the sample through an optical lens.

The 90 degree scattered light by suspended particle is collected by the probe through a second lens and it is converted in an electric signal proportional to the turbidity of the sample.

TU 8325 e TU 8525 probes use an infrared light so the measuring is not effected by the color of the sample.

External light effect

The exposure of the probes to high external light can influence the turbidity measurement.

The circuits of the probe detect the external light that may effect the accuracy of the measuring.

If the effect cannot be automatically compensated, the probe sends an error message and an alarm if the analog operating mode has been selected.

The user must modify the installation in order to protect the lens from the sun or the stray light.

This effect is not present in the model TU 8525 because it is normally installed into the flow cell TU 910 / TU 920 or in pipe.

6.2 OPERATING MODE

The probe can be configured to operate in analog or digital mode.

For operation in analog mode you must configure "digital mode = 0".

For operation in digital mode you must configure "digital mode = 1 o 2".

When a new operating mode has been configured, the new configuration is active after the probe is powered off and back on.

6.3 ANALOG MODE

In analog mode, the probe provides a 4-20 mA output current loop isolated from the sample for direct connection to a PLC or to a data logger.

The probe in the analog mode can be connected to BC 7335 - BC 7635 - BC 7635.010 - BC 7687 - BC 6587 B&C Electronics instruments, which allow the visualization of the measure and have two set point on/off and an alarm window.

The probe is supplied with the factory configuration in analogue mode (digital mode = 0).

The probe requires 2 seconds from the switching on to stabilize the operation of the internal circuits.

After 2 seconds, the current loop settles for the next 16 seconds to set current values that allow the operator to identify the scale of measurement selected in the configuration:

- 8 mA for 0.000 ÷ 4.000 NTU scale;
- 12 mA for 0.00 ÷ 40.00 NTU scale;
- 20 mA for 0.0 ÷ 400.0 NTU scale.

 *If any RS485 serial interface activity is not detected during the time interval of 2 to 18 seconds from the switching on, the probe will enter definitively in analog mode with 4-20 mA current loop ignoring any subsequent activity present on the serial.*

If during this interval an RS485 serial interface activities is detected, the probe will go into digital mode (typical absorption 7 mA, may be higher during transmission).

 With check signal enabled (see "CHECK SIGNAL ACTIVATION (page 30)"), the current loop jumps between 3.8 mA and 21.0 mA every 16 seconds to indicate fouling or dry alarm, high external light or faulty measurement.

The sequence is ended when all the alarm condition are not present.

6.4 DIGITAL MODE

In digital mode the probe is a slave device that interacts with a master device through the RS485 serial interface.

In case of connection to a PC, a RS485/RS232 or RS485/USB (as BC 8701) converter can be required.

The communication is via the RS485 connection with the B&C protocol (ASCII) and Modbus RTU (function 03 - 06 -16) protocol described in the following chapters.

When switched on the probe requires 2 seconds to stabilize its internal circuits.

After that period, if configured for digital mode with the parameter "digital mode = 1" or "digital mode = 2", the probe is ready to receive commands from the master device or manually through the Hyperterminal program or similar.

For digital mode = 1 the current loop will provide 8 / 12 / 20 mA in function of the selected scale.

For digital mode = 2 the current loop will provide 7 mA.

Alarm states are signaled with an error flag in the transmitted record.

6.4.1 B&C COMMUNICATION PROTOCOL

Connect the probe to a PC for data management and calibration, using a simple terminal emulation program (example Hyperterminal).

Mode of transmission

Code system	ASCII
Number of bits per character:	
- start bits	1
- data bits	8
- parity	no parity
- stop bits	1
Error check (only A command)	BCC
Speed	9600 baud (default)

Command format using ID (01 ÷ 99) or (1 ÷ 99)

1 or 2 byte ID probe (01 ÷ 99 or 1 ÷ 99)

1 or 2 byte of command

n byte to be inserted if required by the command

1 byte <cr> (carriage return) end command

The probe transmits only if the ID sent is correct or is 00.

 Do not use 00 ID if more than one probe is connected, to avoid overlap of the communication.

Command format using ID + SNxxxxxx

1 or 2 byte ID probe (01 ÷ 99 or 1 ÷ 99)

8 byte serial number (SNxxxxxx)

1 or 2 byte of command

n byte to be inserted if required by the command

1 byte <cr> (carriage return) end command

The probe transmits only if the ID + serial number sent is correct or if it is 00 + serial number.

 If the communication port is set to a different speed the probe will not communicate.

 *All the available commands are listed in the following pages.*

 *The list of commands implemented in the probe is always available by sending the command Help.*

COMMANDS USING ID

HELP

Command format: ID + H <cr>

Example: if ID=14 type 14H <cr> or 00H <cr>

By sending the command H the probe responds by sending a record containing the list of available commands with a brief description of their meaning.

```
-----
HELP MENU, COMMAND LIST          B&C ELECTRONICS
-----
TU8X25  TURBIDITY PROBE 4.000/40.00/400.0 NTU Rev.fw:3.00  S/N:160589

00H <cr>  Help menu
00A <cr>  Acquisition
00Mx <cr> Digital mode:      0000          (0=analog 1=digital 2=dig.LP)
00Ox <cr> Analog out 4/20mA: 0001          (1=4.000 2=40.00 3=400.0 NTU)
00Xx <cr> Scalable output %: 0100          (10-100% full scale)
00RLx<cr> RT90% large signal 0040 s        (2-220s)
00RSx<cr> RT90% small signal 0120 s        (2-220s)
00Vx <cr> Standard zero NTU: 0.020 NTU     (0.000-4.000 NTU)
00Tx <cr> Standard sens.NTU: 400.0 NTU     (0.000-400.0 NTU)
00Z <cr>  Zero calibration: OK           0.049 (0.4 NTU max) (00ZR reset zero)
00S <cr>  Sens. calibration: not done 100.0% (70-130%) (00SR reset sens)
00C <cr>  Check signal cal.: not done 100.0% (50-200%) (00CR reset check)
00Kx <cr> Check enable:      0000          (0=off 1=on)
00Fx <cr> Check fouling:     0010          (0-100%)
00Yx <cr> Check dry:         0200          (100-200%)
00Dx <cr> Last cal date:     00/00/00      (XX/XX/XX, XX=00-99)
00Ix <cr> ID B&C:            0002          (01-99) or (1-99)
00Ex <cr> ID modbus:         0002          (1-243)
00Bx <cr> Baud rate:         0003          (1=2400 2=4800 3=9600 4=19200)
```

Type ID number or 00 before command. Example, if ID=15 type 15A or 00A <cr>
Use 00A <cr> if only one probe is connected
Query commands: 00H?,00Z?,00S?,00C?

PARAMETERS QUERY

Command format: ID + H? <cr>

Example: if ID=14 type 14H? <cr> or 00H? <cr>

By sending the command H? displays a record containing the code and the identifier followed by all parameters including the results of calibrations.

The record transmitted uses the "," as separator.

Record format:

```
TU8X25- 02,FW:3.00,SN:123456,M:0000,0:0001,X:0100,RL:0040,RS:0120,V: 0
.....+.....|.....+.....|.....+.....|.....+.....|.....+.....|.....+.....|.....+.....|
.020,T: 400.0,Z:not done 0.000NTU ,S:not done 100.0% ,C:n ot don
.....+.....|.....+.....|.....+.....|.....+.....|.....+.....|.....+.....|.....+.....|
e 100.0% ,K:0001,F:0010,Y:0200,D:00/00/00,IA:0002,EA:0002,BA:0003,
.....+.....|.....+.....|.....+.....|.....+.....|.....+.....|.....+.....|.....+.....|
BCC:4BB8,xx
```

TU8X25	Probe code (TU 8325 or TU 8525)
02	Probe identification number (for ID < 10 visualization with blank/zero as first character according to the mode used in setting the ID)

Below are transmitted parameter values measured by the probe with the format NAME PARAMETER: VALUE.

FW:3.00	Firmware version
SN:123456	Probe's serial number
M:0000	Operating mode
O:0001	Analog output/scale setting
X:0100	Scalable output
RL:0040	Large software filter value
RS:0120	Small software filter value
V:0.020	Zero calibration solution value
T:400.0	Sensitivity calibration solution value
Z:not done 0.000NTU	Zero calibration outcome (not done, ok, error)
S:not done 100.0%	Sensitivity calibration outcome (not done, ok, error)
C:not done 100.0%	Check signal calibration outcome (not done, ok, error)
K:0001	Check signal activation
F:0010	Check fouling value
Y:0200	Check dry value
D:00/00/00	Last calibration date
IA:0002	ID B&C protocol
EA:0002	ID Modbus protocol
BA:0003	Baud rate
BCC:4BB8	BCC EEPROM check
xx	2 byte BCC of transmitted record

The record transmission is ended by <cr> <lf>.

EEPROM BCC check use

The EEPROM BCC check is a summary of the probe configuration state. When the parameters are set and calibration has been done, the value of the BCC remains constant until the next change of parameters or calibration. A variation of the BCC value without changing any parameters means the probe's configuration data has been altered.

BCC calculation

The BCC messages sent by the probe is calculated as the XOR of all the bytes making up the message (excluding <cr> and <lf>) and divided into 2 nibble.

The two nibbles are then transformed into their ASCII codes.

The BCC transmitted at the end of record is used to check the validity of records received.

ACQUISITION

Command format: ID + A <cr>

Example: if ID=14 type 14A <cr> or 00A <cr>

By sending the command A, the probe responds by sending a record containing the code, the ID, date, time, and the value of all the measures.

Record format

```
TU8X25- 10 0.0 01/01/01 00:00:00 ± 100.0NTU ± 100.0% ± 20.0°C ±
.....+.....|.....+.....|.....+.....|.....+.....|.....+.....|.....+.....|
      10% ± 200% ± 0err ± 36.0% ± 0err 18/11/10xx
```

TU8x25	Probe code (TU 8325 or TU 8525)
10	Probe ID
0.0	Power voltage (not implemented)
01/01/01	Date (not implemented)
00:00:00	Time (not implemented)

Below are transmitted the parameter values measured by the probe with the following format:

Measuring	- Sign of measure (if positive is sent a blank) - Value of measure (6 characters - right alignment)
Measuring unit	- 4 characters - left alignment - 1 blank (ASCII 32)
± 100.0 NTU	Turbidity value
± 100.0 %	Check signal value
± 20.0 °C	Temperature
± 10 %	Check fouling value
± 200 %	Check dry value
± 0err	Check error 0= no error 1=fouling error 2=dry error
± 36.0 %	Average signal value related to external light
± 0err	Flag error 0= no error 1= high external light error 2= indeterminate measure error

At the end of the record, the probe sends the date the last calibration procedure, then 2 bytes containing the BCC of the string sent.

18/11/10	Last calibration date
xx	2 byte BCC

The record transmission is ended by <cr> <lf>.

BCC calculation

The BCC messages sent by the probe is calculated as the XOR of all the bytes of the message (excluding <cr> and <lf>) and divided into two nibbles.

The two nibbles are then transformed into their ASCII codes.

BCC use

The BCC can be used if you want to create a master program that interrogates the probe.

The BCC is used to check the validity of records received.

DIGITAL MODE

Command format: ID + M + x <cr>

Example: if ID=14 and digital mode = 1 type 14M1 <cr> or 00M1 <cr>

Response of the unit: <cr> <lf> ID + M + x <cr> <lf> command executed correctly

Response of the unit: none command failed

The probe can be configured to operate in digital mode (digital mode = 1 or 2) or in analog 4-20 mA mode (digital mode = 0).

 *For this command, and for all the following commands the response of the sensor is a replica of the command received with the addition of a <lf> line feed (head) at the beginning and end of the response.*

ANALOG OUTPUT

Command format: ID + O + x <cr>

Example: if ID=14 and analog out = 40.00 NTU scale type 14O2 <cr> or 00O2 <cr>

Response of the unit: <cr> <lf> ID + O + x <cr> <lf> command executed correctly

Response of the unit: none command failed

4-20 mA analogue output can be matched to one of the following scales.

Set parameter:

x=1 for 0.000 ÷ 4.000 NTU scale

x=2 for 0.00 ÷ 40.00 NTU scale

x=3 for 0.0 ÷ 400.0 NTU scale

OUTPUT SCALE FACTOR

Command format: ID + X + x <cr>

Example: if ID=14 and scale factor is 50 % type 14X50 <cr> or 00X50 <cr>

Response of the unit: <cr> <lf> ID + X + x <cr> <lf> command executed correctly

Response of the unit: none command failed

To check whether the entered value has been received type command H? or H.

SENSITIVITY SOLUTION VALUE

Command format: ID + T + x <cr>

Example: if ID=14 and the calibration solution is 100.0 NTU type 14T100.0 <cr> or 00T100.0 <cr>

Response of the unit: <cr> <lf> ID + T + x <cr> <lf> command executed correctly

Response of the unit: none command failed

To check whether the entered value has been received type command H? or H.

ZERO CALIBRATION

Perform the zero calibration with standard solution of zero or with a known turbidity solution.

The value of the solution should be inserted through the command "Zero solution value".

The zero calibration is performed on all three scales starting from the lower one.

 *Zero calibration should be performed before sensitivity calibration.*

Command format: ID + Z <cr>

Example: if ID=14 type 14Z <cr> or 00Z <cr>

Response of the unit: <cr> <lf> ID + Z <cr> <lf> command executed correctly

Response of the unit: none command failed

Possible results:

'ok'	calibration done
'error'	error during calibration
'not done'	default factory calibration value

To check the result of the zero calibration using the Z?, H? or H

In the event of a successful test with the A, the reading in NTU must be close to the solution used for calibration.

 *If the operation has failed (error) is kept the value of the previous zero.*

Inspect the state of the surface of the lenses and, if necessary, clean the surface with a soft cloth.

ZERO CALIBRATION RESET

Command format: ID + ZR <cr>

Example: if ID=14 type 14ZR <cr> or 00ZR <cr>

- 💡 *If the operation has failed (error) check that the probe is actually immersed in the standard solution.
Inspect the state of the surface of the lenses and, if necessary, clean the surface with a soft cloth.
In the case of a negative result the probe restores the previous values of sensitivity.*

SENSITIVITY CALIBRATION RESET

Command format: ID + SR <cr>

Example: if ID=14 type 14SR <cr> or 00SR <cr>

Response of the unit: <cr> <lf> ID + SR <cr> <lf> command executed correctly
Response of the unit: none command failed

This command allows to return to the default sensitivity value of 100.0 %.

Verify the outcome of the operation through the command S?, H? o H and check the line "Sens. calibration: not done".

SENSITIVITY CALIBRATION TEST

Command format: ID + S? <cr>

Example: if ID=14 type 14S? <cr> or 00S? <cr>

Response of the unit: <8 characters outcome> command executed correctly
 >blank> <7 characters value>
 <4 characters measure
 unit><cr> <lf>
Response of the unit: none command failed

Record format

```
ok            ± 100.0%  
.....+.....|.....+.....|.....+.....|.....+.....|.....+.....|.....+.....|.....+.....|
```

Possible results: ok / not done / error.

CHECK SIGNAL CALIBRATION

Before performing the calibration check the condition of the surface of the lenses and, if necessary, clean with a soft cloth.

The probe must be properly immersed in the liquid without the presence of air bubbles on the surface of the lenses.

Command format: ID + C <cr>

Example: if ID=14 type 14C <cr> or 00C <cr>

Response of the unit: <cr> <lf> ID + C <cr> <lf> command executed correctly
Response of the unit: none command failed

Possible results:

'ok'	calibration done
'error'	error during calibration
'not done'	default factory calibration value

The "Check signal cal.: not done" message will mean the parameter is turned to the default value through the command C?, H? o H.

In case of a positive outcome 'ok' check with the command A, the check signal reading should be about 100%.

CHECK SIGNAL RESET

Command format: ID + CR <cr>

Example: if ID=14 type 14CR <cr> or 00CR <cr>

Response of the unit: <cr> <lf> ID + CR <cr> <lf> command executed correctly

Response of the unit: none command failed

This command is for turning the check signal to the default value 100%.

To verify the calibration results of the control signal using the C?, H? Or H and check the line "Check signal cal.: not done."

CHECK SIGNAL CALIBRATION TEST

Command format: ID + C? <cr>

Example: if ID=14 type 14C? <cr> or 00C? <cr>

Response of the unit: <8 characters outcome> command executed correctly
>blank> <7 characters value>
<4 characters measure
unit><cr> <lf>

Response of the unit: none command failed

Record format

```

ok           ± 100.0%
.....+.....|.....+.....|.....+.....|.....+.....|.....+.....|.....+.....|.....+.....|

```

Possible results: ok / not done / error.

CHECK SIGNAL ACTIVATION

Command format: ID + K + x <cr>

Example: if ID=14 and you want to enable the check signal type 14K1 <cr> or 00K1 <cr>

Response of the unit: <cr> <lf> ID + K + x <cr> <lf> command executed correctly

Response of the unit: none command failed

Set the parameter:

x=0 to disable the check signal

x=1 to enable the check signal

The enable check signal allows to have information about:

- dirty or damaged lens' surface (see the command "Check fouling" to set the alarm limit);
- the probe is not well immersed into the sample or there are air bubbles close to the lens (see the command "Check dry" to set the alarm limit);
- the ambient light is too high and saturates the turbidity signal.

CHECK FOULING

Command format: ID + F + x <cr>

Example: if ID=14 and you want to set the alarm for dirty cell to 10% of the check signal type 14F10 <cr> or 00F10 <cr>

Response of the unit: <cr> <lf> ID + F + x <cr> <lf> command executed correctly

Response of the unit: none command failed

Command for setting the alarm limit of the dirty or damaged lens surface.

CHECK DRY

Command format: ID + Y + x <cr>

Example: if ID=14 and you want to set the alarm for dry cell to 150 % of the check signal type 14Y150 <cr> or 00Y150 <cr>

Response of the unit: <cr> <lf> ID + Y + x <cr> <lf> command executed correctly

Response of the unit: none command failed

Command for setting the alarm limit of the dry cell or air bubble presence near the lens.

LAST CALIBRATION DATE

Command format: ID + D + XX/XX/XX <cr> (XX = 00 ÷ 99)

Example: if ID=14 and the date to be inserted is 11/05/18 type 14D11/05/18 <cr> or 00D11/05/18 <cr>

Response of the unit: <cr> <lf> ID + D + XX/XX/XX <cr> <lf> command executed correctly

Response of the unit: none command failed

This command allows to store the last calibration date.

The date field is 8 characters to be written in the proposed format.

ID OF THE B&C PROTOCOL

Command format: ID + I + x <cr>

Example: if ID=14 and the new ID (identification) to enter is 07 type 14I07 <cr> or 00I07 <cr>

Response of the unit: <cr> <lf> ID + I + x <cr> <lf> command executed correctly

Response of the unit: none command failed

If ID is less than 10 depending on the input mode the first digit will then be displayed as blank or zero in controls 00A and 00H?.

If you want a view with a zero first you must enter the ID with 0 as 00I07 but if you want it with the blank you have to type it without 0 example 00I7.

The probe activates the new ID immediately after the response to the command.

ID OF THE MODBUS PROTOCOL

Command format: ID + E + x <cr>

Example: if ID=14 and the new ID (identification) to enter is 07 type 14E07 <cr> or 00E07 <cr>

Response of the unit: <cr> <lf> ID + E + x <cr> <lf> command executed correctly

Response of the unit: none command failed

The probe activates the new ID immediately after the response to the command.

BAUD RATE

Command format: ID + B + x <cr>

Example: if ID=14 and the new speed is 2 = 4800 baud type 14B2 <cr> or 00B2 <cr>

Response of the unit: <cr> <lf> ID + B + x <cr> <lf> command executed correctly

Response of the unit: none command failed

The probe activates the new baud rate immediately after the response to the command.

Set parameter:

x=1 for 2400 baud

x=2 for 4800 baud

x=3 for 9600 baud

x=4 for 19200 baud

6.4.2 MODBUS PROTOCOL

On the probe, in addition to the ASCII B&C protocol, is implemented the Modbus RTU protocol limited to the function 03, 06, and 16.

In Modbus communication network the probe operates as a slave device.

RTU transmission mode

Coding system	8-bit binary
Number of bits per character:	
- start bits	1
- data bits (minus sign before)	8
- parity	no parity
- stop bits	1
Errors verification	CRC-16

RTU messages format

Pause transmission	duration 3,5 bytes
Address	1 byte (8 bits)
Function	1 byte (8 bits)
Data	N bytes (N x 8 bits)
Errors verification	2 bytes (16 bits)
Pause transmission	duration 3,5 bytes

For a correct synchronization of the transmission the receiving unit interprets the end of a message when it doesn't receive any characters (bytes) for a time equivalent to the transmission of 3.5 characters (bytes).

MODBUS FUNCTION 03 (0x03)

Function 03 (MASTER QUERY)

Address	1 byte	1 ÷ 243 (probe ID)
Function	1 byte	03 (read holding register)
Start address data HI	1 byte	Start address of registers
Start address data LO	1 byte	
Number of registers HI	1 byte	Number of registers (2 byte x register)
Number of registers LO	1 byte	
Errors verification	2 bytes	CRC-16

The probe considers valid the message if CRC-16 valid, ID valid and function=03.

Function 03 (SLAVE ANSWER)

Address	1 byte	1 ÷ 243 (probe ID)
Function	1 byte	03 (read holding register)
Number of byte of sent data	1 byte	2x number of sent registers
N byte of data	N byte	Values of registers
Error verification	2 bytes	CRC-16

If you query requesting registers outside the defined limits, the probe answers assigning zero to all of the registers out of range.

If an error occurs in the request, the response takes the following form:

Address	1 byte	1 ÷ 243 (probe ID)
Function	1 byte	0x83 (read holding register + error)
Error	1 byte	2 = illegal data address 3 = illegal data value
Error verification	2 bytes	CRC-16

Time between the end of the query and the beginning of the response about 100 ms.

MODBUS FUNCTION 06 (0x06)

Function 06 (MASTER QUERY)

Address	1 byte	1 ÷ 243 (probe ID)
Function	1 byte	06 (write single register)
Address data HI	1 byte	Address of the register
Address data LO	1 byte	
Value of the register HI	1 byte	Value to be written
Value of the register LO	1 byte	
Errors verification	2 bytes	CRC-16

The probe considers valid the message if CRC-16 valid, ID valid and function=06.

Function 06 (SLAVE ANSWER)

Address	1 byte	1 ÷ 243 (probe ID)
Function	1 byte	06 (write single register)
Address data HI	1 byte	Address of the register
Address data LO	1 byte	
Value of the register HI	1 byte	Value to be written
Value of the register LO	1 byte	
Errors verification	2 bytes	CRC-16

When writing some calibration commands (eg zero calibration), the probe responds to the request and then remains silent for the time necessary to perform the operation.

If an error occurs in the request, the response takes the following form:

Address	1 byte	1 ÷ 243 (probe ID)
Function	1 byte	0x86 (write single register + error)
Error	1 byte	2 = illegal data address 4 = slave device failure
Error verification	2 bytes	CRC-16

Time between the end of the query and the beginning of the response about 100 ms.

MODBUS FUNCTION 16 (0x10)

Function 16 (MASTER QUERY)

Address	1 byte	1 ÷ 243 (probe ID)
Function	1 byte	16 (write multiple registers)
Start address data HI	1 byte	Start address of registers
Start address data LO	1 byte	
Number of registers HI	1 byte	Number of registers (2 byte x register)
Number of registers LO	1 byte	
Number of byte	1 byte	2 byte per register
Value of registers	n byte	n = 2 byte x number of registers
Errors verification	2 bytes	CRC-16

The probe considers valid the message if CRC-16 valid, ID valid and function=16.

Function 16 (SLAVE ANSWER)

Address	1 byte	1 ÷ 243 (probe ID)
Function	1 byte	16 (write multiple registers)
Start address data HI	1 byte	Start address of registers
Start address data LO	1 byte	
Number of registers HI	1 byte	Number of registers (2 byte x register)
Number of registers LO	1 byte	
Errors verification	2 bytes	CRC-16

When writing some calibration commands (eg zero calibration), the probe responds to the request and then remains silent for the time necessary to perform the operation.

If an error occurs in the request, the response takes the following form:

Address	1 byte	1 ÷ 243 (probe ID)
Function	1 byte	0x90 (write multiple registers + error)
Error	1 byte	2 = illegal data address 3 = illegal data value 4 = slave device failure
Error verification	2 bytes	CRC-16

Time between the end of the query and the beginning of the response about 100 ms.

BROADCAST COMMANDS

Modbus 06 and 16 queries can be made by the master in broadcast mode.

The broadcast mode consists in sending the message with the identifier 0, all the probes perceive the message and execute the command but do not respond to the master in order not to create conflicts.

MODBUS REGISTERS

MEASURE AND STATE (address 0x00xx)

	Mod-bus address	Parameter	Range	Unit	Scale	Data type	R/W
1	0x0000	Turbidity NTU	0 ÷ 4000	NTU	a	IS	R
2	0x0001	Scale	1 ÷ 3 ^b			IS	R
3	0x0002	Check signal %	0 ÷ 2200	0.1	0.0 ÷ 220.0 %	IS	R
4	0x0003	Temperature °C	0 ÷ 500	0.1	0.0 ÷ 50.0 °C	IS	R
5	0x0004	Check fouling %	0 ÷ 100	1	0 ÷ 100 %	IS	R
6	0x0005	Check dry %	100 ÷ 200	1	100 ÷ 200 %	IS	R
7	0x0006	Check error	0 ÷ 2 ^c			IS	R
8	0x0007	External light value %	0 ÷ 1000	0.1	0.0 ÷ 100.0 %	IS	R
9	0x0008	External light error	0 ÷ 2 ^d			IS	R
10	0x0009	BCC EEPROM	0 ÷ 65535	1	0 ÷ 65535	I	R

^a = depend on the configured scale

^b = 1: 0.000 ÷ 4.000 NTU scale / 2: 0.00 ÷ 40.00 NTU scale / 3: 0.0 ÷ 400.0 NTU scale

^c = 0: no error / 1: fouling error / 2: dry cell error

^d = 0: no error / 1: high external light error / 2: indetermin. measure error

IS = integer signed / I = integer

R = read / W = write

ZERO CALIBRATION (address 0x010x)

	Mod-bus address	Parameter	Range	Unit	Scale	Data type	R/W
11	0x0101	Standard zero	0 ÷ 4000	0.001	0 ÷ 4.000 NTU	IS	R/W
12	0x0102	Zero command/flag - zero cal - reset zero - flag zero cal	0x5A00 0x5A52 0 = not done 1 = ok 2 = error	1 1 1		I	W W R
13	0x0103	Zero value - scale 1 - scale 2 - scale 3	-400 ÷ 400 -40 ÷ 40 -4 ÷ 4	0.001 0.01 0.1	-0.4 ÷ 0.4 NTU -0.4 ÷ 0.4 NTU -0.4 ÷ 0.4 NTU	IS	R

IS = integer signed / I = integer

R = read / W = write

SENSIBILITY CALIBRATION (address 0x011x)

	Mod-bus address	Parameter	Range	Unit	Scale	Data type	R/W
14	0x0112	Decimal point standard sens.	1 ÷ 3	1		IS	R/W
15	0x0113	Standard sens - decimal point = 1 - decimal point = 2 - decimal point = 3	0 ÷ 4000 0 ÷ 4000 0 ÷ 4000	0.1 0.01 0.001	0.0 ÷ 400.0 NTU 0.00 ÷ 40.00 NTU 0.000 ÷ 4.000 NTU	IS	R/W
16	0x0114	Sens command/flag - sens cal - reset sens - flag sens cal	0x5300 0x5352 0 = not done 1 = ok 2 = error	1 1 1		I	W W R
17	0x0115	Sens value	700 ÷ 1300	0.1	70.0 ÷ 130.0 %	IS	R

IS = integer signed / I = integer

R = read / W = write

CHECK CALIBRATION (address 0x012x)

	Mod-bus address	Parameter	Range	Unit	Scale	Data type	R/W
18	0x0120	Check command/flag - check cal - reset check - flag check cal	0x4300 0x4352 0 = not done 1 = ok 2 = error	1 1 1		I	R/W
19	0x0121	Sens value	500 ÷ 2000	0.1	50.0 ÷ 200.0 %	IS	R

IS = integer signed / I = integer

R = read / W = write

SETUP (address 0x020x)

	Mod-bus address	Parameter	Range	Unit	Scale	Data type	R/W
20	0x0200	Large filter	2 ÷ 220	1	2 ÷ 220 s	IS	R/W
21	0x0201	Small filter	2 ÷ 220	1	2 ÷ 220 s	IS	R/W

IS = integer signed / I = integer

R = read / W = write

TU 8X2X SETUP (address 0x021x)

	Mod-bus address	Parameter	Range	Unit	Scale	Data type	R/W
22	0x0210	Check enable	0 = OFF 1 = ON	1		IS	R/W
23	0x0211	Check fouling %	0 ÷ 100	1	0 ÷ 100 %	IS	R/W
24	0x0212	Check dry %	100 ÷ 200	1	100 ÷ 200 %	IS	R/W

IS = integer signed / I = integer

R = read / W = write

CONFIGURATION (address 0x030x)

	Mod-bus address	Parameter	Range	Unit	Scale	Data type	R/W
25	0x0300	Digital mode	0 = analog 1 = digital 2 = dig.lo power	1		IS	R/W
26	0x0301	Scale	1 ÷ 3	1		IS	R/W
27	0x0302	Scalable output	10 ÷ 100	1	10 ÷ 100 %	IS	R/W
28	0x0303	Baud rate	1 = 2400 2 = 4800 3 = 9600 4 = 19200	1		IS	R/W
29	0x0304	ID B&C	1 ÷ 99	1		IS	R/W
30	0x0305	ID Modbus RTU	1 ÷ 243	1		IS	R/W

IS = integer signed / I = integer
 R = read / W = write

INFO PROBE (address 0x040x)

	Mod-bus address	Parameter	Range	Unit	Scale	Data type	R/W
31	0x0401	Code	6 characters			I	R
32	0x0404	Serial number	6 characters			I	R
33	0x0407	Rev. fw	4 characters			I	R
35	0x0409	Last cal date (1)	00 ÷ 99	1		IS	R/W
36	0x040A	Last cal date (2)	00 ÷ 99	1		IS	R/W
35	0x040B	Last cal date (3)	00 ÷ 99	1		IS	R/W

IS = integer signed / I = integer
 R = read / W = write

Use of BCC EEPROM

The EEPROM BCC check is the probe configuration state synthesis. After setting the parameters and carry out the calibration the value of the BCC remains constant until the next change of parameters or calibration.

A variation of BCC in the absence of changes warns that an alteration has taken place in the probe configuration data.

7 MAINTENANCE

The two optical lenses at the bottom of the probe should be inspected and cleaned periodically.

Cleaning is recommended before zero and sensitivity calibration.

Remove any deposit on the optical lens by using a soft, damp cloth or paper towel without pushing on the surface to avoid scratching it.

If necessary, use a soft detergent or a very dilute acid if the deposits are of limestone type.

The frequency of cleaning depends on the type of use, the nature and the concentration of the measuring sample.

The probe TU 8325 is designed for automatic cleaning by means of an external system that sends air to the probe. Do not exceed the pressure of 3 bar and the duration of 10 seconds.

Contact our sales department for more information.



During these operations avoid removing the cable gland.

This removal is reserved to the manufacturer and if carried out by the operator it will damage the internal circuits voiding the warranty.

7.1 CALIBRATION

The probe is supplied with a factory calibration of the zero and sensitivity done with known standard solutions.

Checking and periodic calibration of the probe is always necessary to ensure the accuracy of the measure.

The optical components can have small drifts during the life.

The cleanliness of the optical lens is an important element to check before making a new calibration. If necessary, clean them with a soft cloth.

Is suggested to run the zero calibration before the sensitivity calibration.

The check signal calibration must be performed with the probe immersed in the liquid without the presence of air bubbles on the surfaces of the optical lens.

Zero calibration

The zero calibration must be performed in the zero standard solution or in water with known turbidity value next to zero.

Calibration is performed on all the scales following the procedures described in chapter "ZERO CALIBRATION (page 27)".

Sensitivity calibration

It is done in formazine solution or in a known turbidity value solution following the procedure in chapter "SENSITIVITY CALIBRATION (page 28)".

We recommend values not lower than 2 NTU.

Use of the dry turbidity simulator TU 9632

TU 9632 is designed to verify calibration and the correct readout of the turbidity systems without the use of standard liquids.

If permitted by the plant or by the installation site, the operator can also use this device as a secondary standard. In this case the user must first calibrate the system with a known formazine standard or similar, and then record the readout obtained when the sensor is placed inside TU9632. This same value can then be used to calibrate the same system.

If the plant or installation require that calibration must be done exclusively with primary standards, the operator can still use TU9632 to periodically check the system is working properly.

Reset of zero and sensitivity calibration

To reset the zero and the sensitivity to factory settings follow the procedures described in chapters "ZERO CALIBRATION RESET (page 27)" and "SENSITIVITY CALIBRATION RESET (page 29)".

8 INSTALLATION DRAWINGS

8.1 TU 8325 - DIMENSIONS

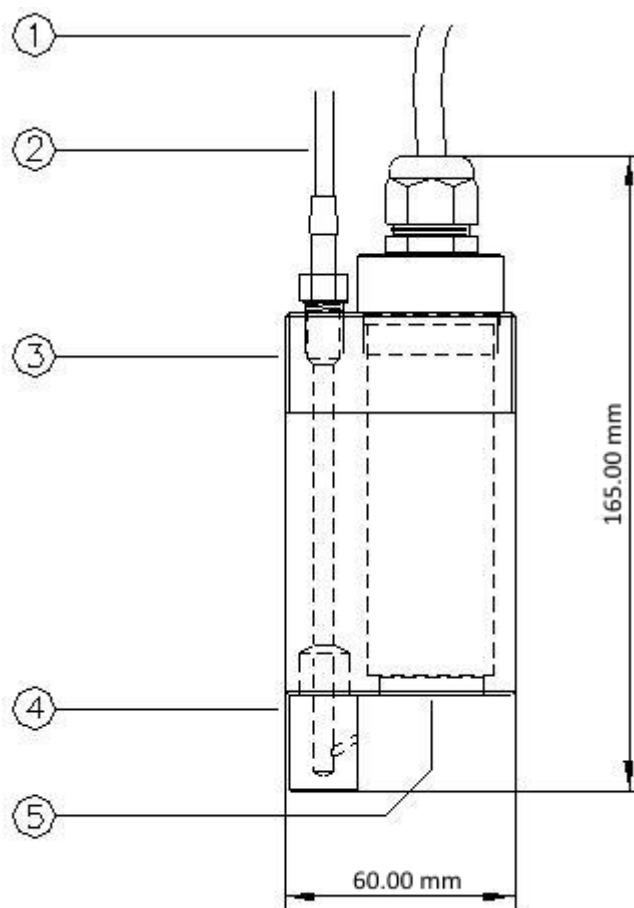

Description

- 1 Cable
- 2 Air input
- 3 Thread
- 4 Air nozzle
- 5 Optical lens

Connections

- Shield not connected
- Yellow RS485 A (+)
- Grey RS485 B (-)
- Brown not connected
- Green + current loop
- White - current loop / COM RS485

8.2 TU 8325 - TYPICAL INSTALLATION

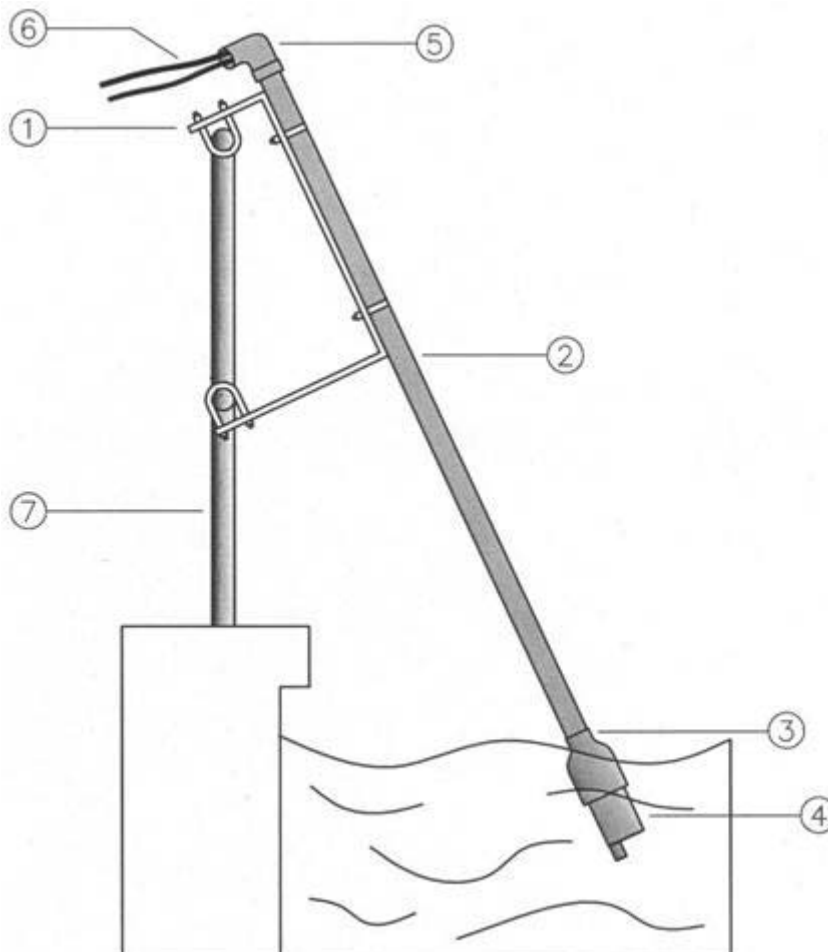

- 1 Swivel mounting (0012.000624)
- 2 Extension pipe
- 3 Adapter (0012.450043)
- 4 Turbidity sensor with autoclean nozzle
- 5 Rain protection
- 6 Cable and air tubing
- 7 Rail

8.3 TU 8525 - DIMENSIONS

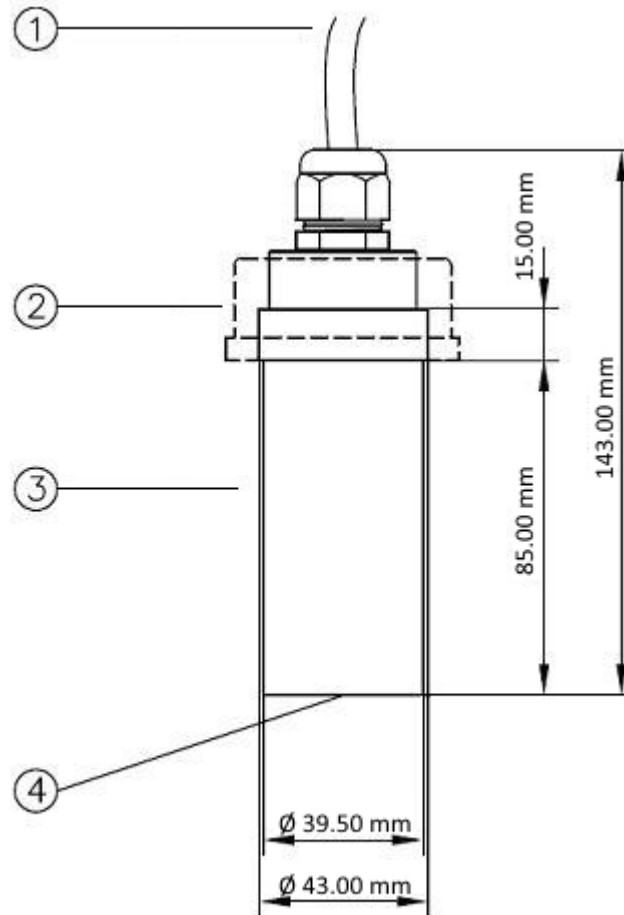

Description

- 1 Cable
- 2 Thread
- 3 Air nozzle
- 4 Optical lens

Connections

- Shield not connected
- Yellow RS485 A (+)
- Grey RS485 B (-)
- Brown not connected
- Green + current loop
- White - current loop / COM RS485

8.4 ANALOG MODE WIRING

The connection shown in the figure is possible for all models.

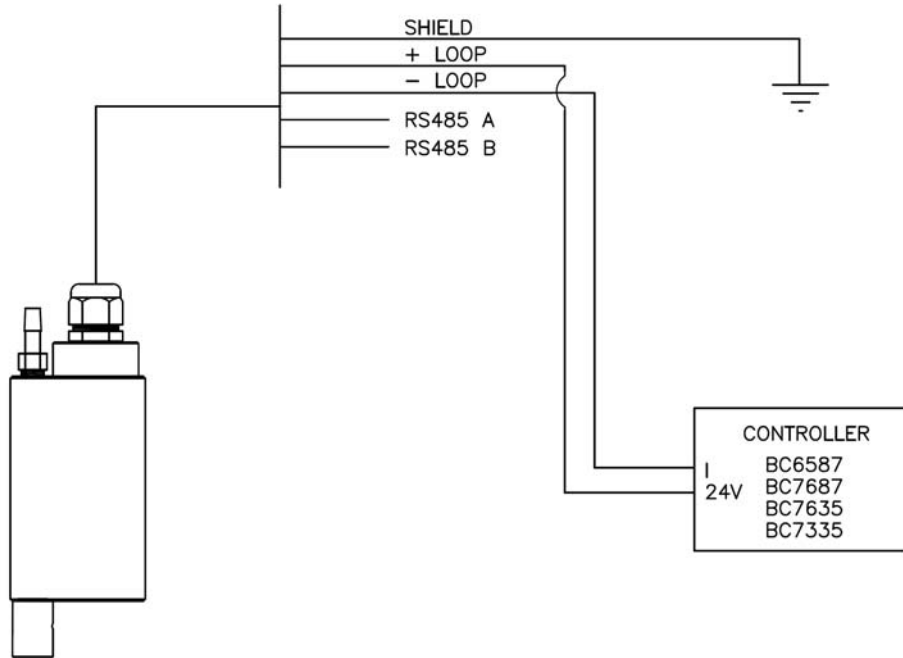

Connection to B&C Electronics' instruments

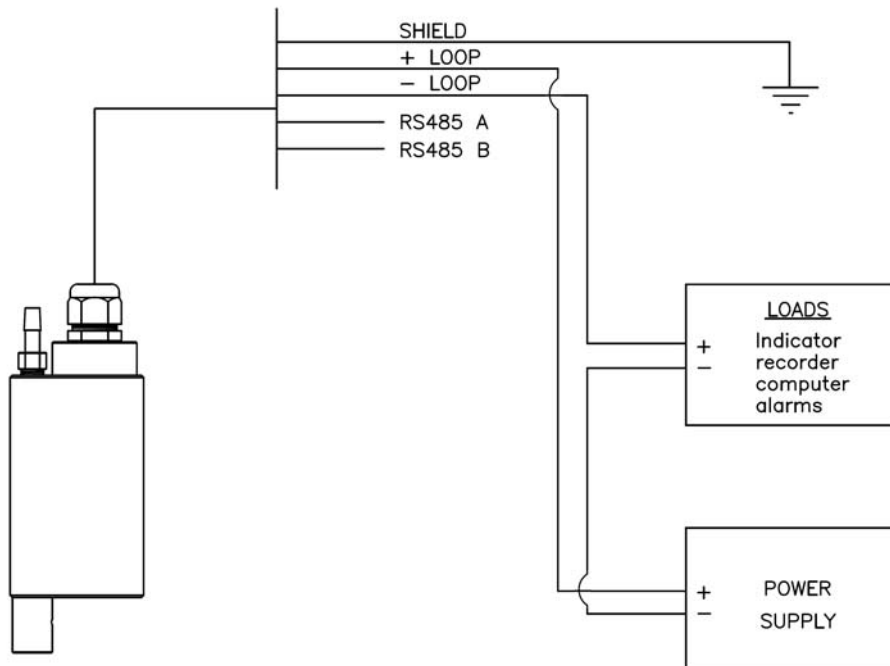

Connection to PLC or data logger

8.5 DIGITAL MODE WIRING

The connection shown in the figure is possible for all models.

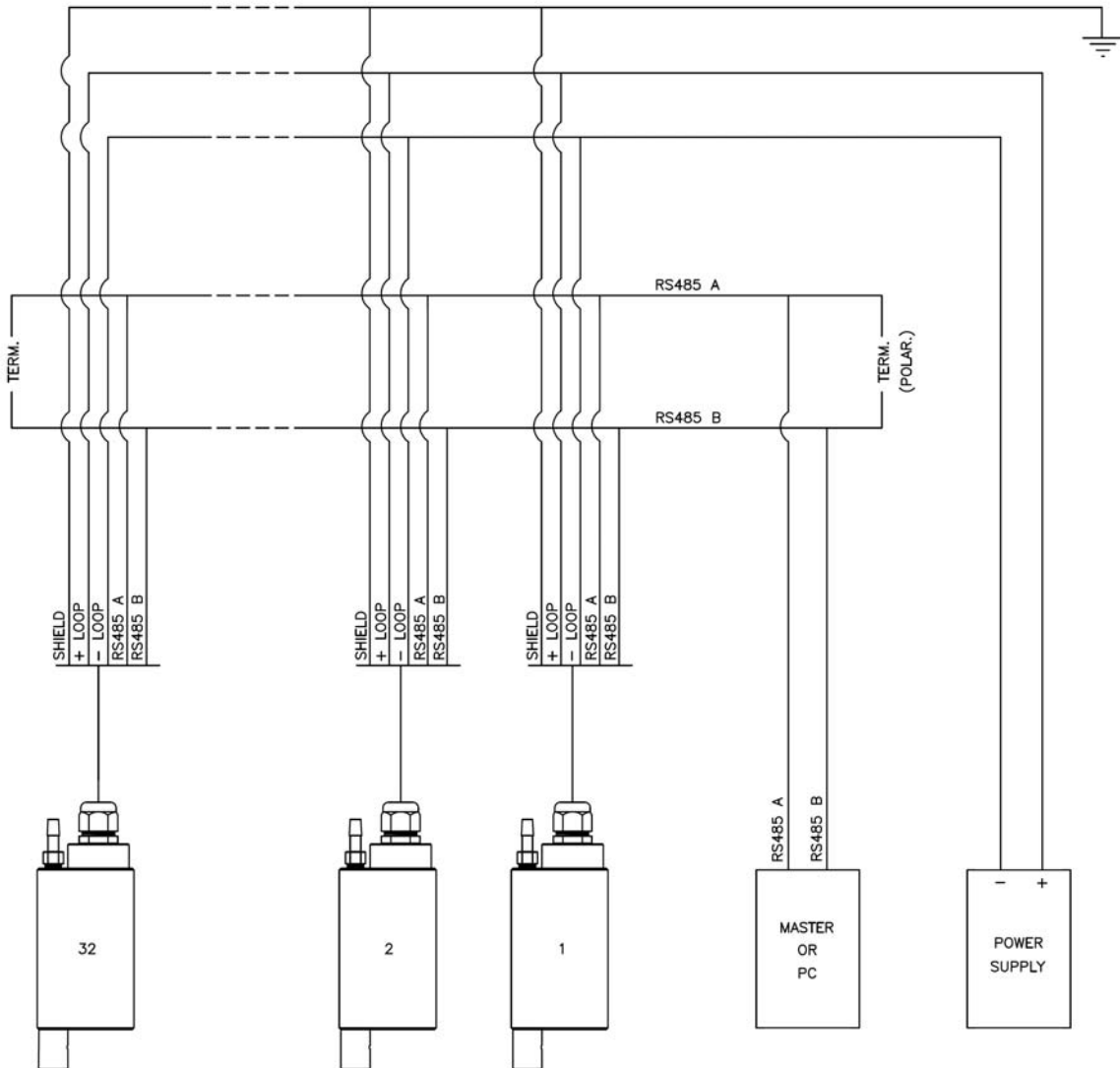

9 WARRANTY

- 1 Your product is guaranteed for 5 years from the date of purchase, for failure due to manufacturing defects.
 - 2 The warranty is void in case of tampering or deterioration due to improper installation or maintenance.
 - 3 The warranty covers only free repair at the laboratories of the manufacturer.
 - 4 B&C Electronics is not liable for any damage arising from misusing its instruments and products.
-

10 REPAIRS

For faster and efficient service it is recommended to fill in the "Information card" for the repair service and attach it to a "Repair order".

- 1 The estimated cost, if required by the customer, is free if the repair is confirmed. Otherwise flat rate results in a charge for the analytical work performed and expenses incurred.
- 2 The products to be repaired must be sent to B&C Electronics with freight prepaid. Any expenses incurred on behalf of the client and not previously agreed will be charged.
- 3 Our sales department will submit to the customer the repair estimate or offer a replacement in the following cases:
 - repair cost is considered excessive in relation to the cost of the product;
 - the repair is technically impossible or unreliable.
- 4 In order to reduce the time of delivery of the repaired products, unless otherwise offered or arranged by the customer, the shipment will be made with ex-factory, prepaid carriage by a courier.

INFORMATION SHEET
for service repairs

In the event of a fault, we recommend you contact our repair service, to photocopy and complete this information sheet to be attached to the product to be repaired.

ESTIMATE

REPAIR

COMPANY NAME

ADDRESS

ZIP

TOWN

REFER TO MR/MRS

TELEPHONE

MODEL

S/N

DATE

Consult the instruction manual to identify the area of the defect and/or describe it:

SENSOR

ANALOG OUTPT

POWER SUPPLY

SET POINT

CALIBRATION

RELAYS CONTACTS

DISPLAY

INTERMITTENT PROBLEM

DESCRIPTION OF THE DEFECT

.

.

.

.

.

.



B&C Electronics s.r.l. – Via per Villanova 3 – 20866 Carnate (MB) – Italia
Tel. +39 039 631 721 – Fax +39 039 607 6099 – bc@bc-electronics.it – www.bc-electronics.it