



ES-FLOW™

Low-Flow Ultrasonic Flow Meters / Controllers for Liquids



› Ultrasonic flow meter for low flow rates

The innovative ES-FLOW™ Ultrasonic Liquid Flow Meter/Controller is designed for measuring volume flow ranges between 4 and 2-1500 ml/min with high precision, high linearity and low pressure drop using Ultrasonic Wave Technology in a small bore tube.

Liquids can be measured independent of fluid density, temperature and viscosity. Therefore, recalibration per fluid is unnecessary as the instrument is able to detect the actual speed of sound of the measured liquid. With these features the ES-FLOW™ has many similarities with our Coriolis technology based instruments, which are very beneficial compared to Magnetic flow meters or other types of flow meters. With the ES-FLOW™ non-conductive liquids like hydrocarbons, demineralized water and oil-based additives can be measured.

› Improved ES-FLOW™ Mk II

The know-how and experience gained in our specialized domain of developing and manufacturing flow meters have been used to improve the overall performance, hygienic design and accuracy of our ultrasonic flow measurement technology.

The new and improved sensor technology meets the highest hygienic standards and is almost twice as accurate at the lower range, as the reading accuracy and the zero stability have been greatly improved.

The ES-FLOW™ is available in two versions. The ES-103I is suitable for hygienic purposes, whereas the ES-113I can cover all other areas. The differences lie in certifications and the available process connections. The sensor technology and performance are similar.

› Designed and authorized for hygienic applications

The ES-103I Mk II is designed for applications with the highest hygienic demands. This is achieved by using stainless steel materials and a straight sensor tube design. The acoustic actuators are positioned at the outer surface, meaning no obstacles or other kind of materials are within the flow path of sensor. The instrument is self-draining, easy to clean and contains zero dead volume. The exterior design is rated to IP66 as well as IP67.

- ◆ 3-A authorized
- ◆ EC 1935-2004
- ◆ Stainless steel wetted parts, no elastomers
- ◆ CIP/SIP compatible
- ◆ Surface quality wetted parts Ra <0.8 µm



› Fields of application

The ES-FLOW™ can be used for a wide variety of applications. Typical applications can be found in Food, Beverage & Pharma for measurement/control of: natural additives, solvents, carbonated liquids, H₂O₂ sterilization, demineralized water and liquids with suspended particles.

› Ultrasonic Wave Technology

The operation of Bronkhorst® ES-FLOW™ flow meters is based on the propagation of ultrasound waves inside a very small, straight sensor tube, without obstructions or dead spaces. At the outer surface of the sensor tube multiple transducer discs are located which create ultrasonic sound waves by radial oscillation.



Every transducer can send and receive, therefore all up- and down-stream combinations are recorded and processed. By accurately measuring the time difference between the recordings (nanosecond range) the flow velocity and speed of sound is calculated. Knowing these parameters and the exact tube cross-section, the ES-FLOW™ is able to measure liquid volume flows in the range of 4 up to 2-1500 ml/min.

The distinctive character of this flow meter is that it's capable to measure the actual speed of sound, meaning that the technology is liquid independent and calibration per fluid is not necessary.

› Benefits of the ES-FLOW™

- ◆ Direct volume flow measurement, independent of fluid properties
- ◆ Lowest flow ranges on the market (ultrasonic principle): 2...1500 ml/min on-site re-rangeable
- ◆ Hygienic design, IP67 rating, CIP/SIP cleanable, self-drainable
- ◆ Very small internal volume (ca. 2 ml), no dead volumes
- ◆ Compact and easy to install
- ◆ Integrated digital (PID) controller for accurate flow or batch delivery
- ◆ Fast response time and cycle times <10 ms.
- ◆ Excellent repeatability and long-term stability
- ◆ Additional temperature output
- ◆ Bi-directional measurement
- ◆ Integrated counter/totalizer functions
- ◆ Reduced downtime: no recalibration required after fluid change



Food, Beverage & Pharma

Customers which require a hygienic design

H₂O₂ for sterilization

Water solutions & demineralized water

Control of metering pumps

Confectionery applications (additive control)



Chemical

Volume flow measurement in applications with a vibrating environment



Surface Treatment

Thermal spraying

Powder in liquid applications



Miscellaneous

Fuel consumption

Paper industry

Leak detection

Diaphragm testing

› Technical specifications

Measurement / control system

Minimum full scale flow	100 ml/min
Maximum full scale flow	1500 ml/min
Minimum flow (controller)	2 ml/min
Volume flow accuracy*	≤ ±0.8% Rd
Zero stability	≤ ±0.4 ml/min
Repeatability	≤ 0,1% Rd ± 0,05 ml/min
Turndown ratio	digital: 2:200 up to 2:1500 ml/min (full scale value scalable by the user); analog: 1:50 (2...100%);
Fluids	liquids with sound speed between 1000 and 2000 m/s; fluid independent measurement; also suitable for non-conductive fluids
Response time	< 200 msec (meter, τ98%)
Refresh (cycle) time	≤ 10 msec
Fluid temperature max	-10...90 °C
Cleaning temperature max	140 °C
Ambient temperature max	0...60 °C
Mounting	Any position, attitude sensitivity negligible.
Temperature accuracy	± 1 °C
Warm-up time	approx. ½ hour after power up for optimum performance

* Reference conditions: demineralized water, 21±3°C en 8±1 bar

Mechanical parts

Sensor	Straight tube
Material (wetted parts)	Stainless steel 316L
Surface quality	≤ 0,8 µm
Pressure rating (PN)	ES-103I: 10 bar(g) (higher on request) ES-113I: 100 bar(g)
Process connections	ES-103I: ½" or ¼" Tri-Clamp flanges ES-113I: 3 mm, 6 mm, ⅜", ¼" OD compression type
Seals	None
Weight	Meter: 1,3 kg; Controller: on request
Ingress protection	IP66 and IP67

Electrical properties

Power supply	+15...24 Vdc ±10%; max. ripple recommended: 50 mV tt
Max. power consumption	2,8 W
Analog output	0...5 (10) Vdc, min. load impedance > 2 kΩ; 0 (4)...20 mA (sourcing), max. load impedance < 375 Ω
Analog setpoint	0...5 (10) Vdc, min. load impedance > 100 kΩ; 0 (4)...20 mA, load impedance ~100 Ω
Customised I/O	Analog control signal output: 0...10 Vdc or 4...20 mA; Pulse output
Digital communication	Standard: RS232; Options: PROFIBUS DP, PROFINET, CANopen®, DeviceNet™, Modbus RTU/ASCII or FLOW-BUS

Electrical connections

Analog, RS232	8-pin M12 Connector (male)
Configured I/O, Actuator output	8-pin M12 Connector (male)
Actuator, Remote display	4-pin M8 connector (female)
PROFIBUS DP	bus: 5-pin M12 connector (female); power: 8-pin M12 connector (male)
CANopen®, DeviceNet™	5-pin M12 connector (male)
FLOW-BUS, Modbus-RTU/ASCII	5-pin M12 connector (male)

Certificates/Approvals

Sanitary/Hygienic Standards	3-A (ES-103I)
Food contact	EC 1935/2004

› Dimensions (in mm)

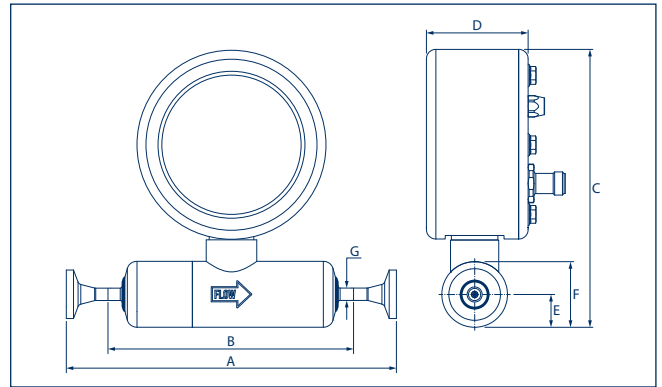

ES-FLOW™ model ES-103I

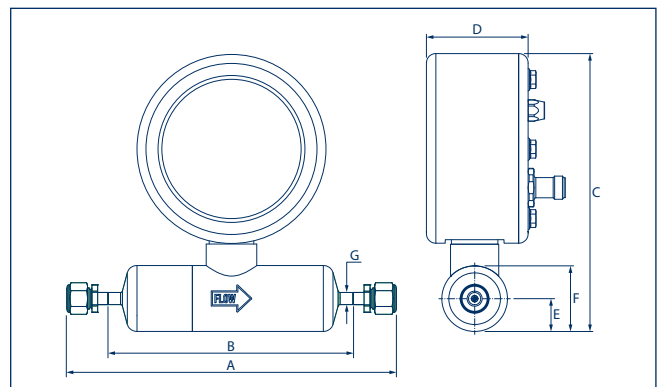

ES-FLOW™ model ES-113I

A	¼" and ½" Tri-Clamp (DIN32676-C)	172,4 mm
	¼" Face Seal male	194,7 mm
	⅜" and ¼" OD compression type	191,0 mm
	3 mm and 6 mm OD compression type	191,0 mm
B		132,4 mm
C		145 mm
D		52,4 mm
E		17 mm
F		Ø34 mm
G		Ø6,35 mm (internal Ø4,57 mm)

Although all specifications in this brochure are believed to be accurate, the right is reserved to make changes without notice or obligation.
Patents pending.

› Flow rate vs Pressure drop

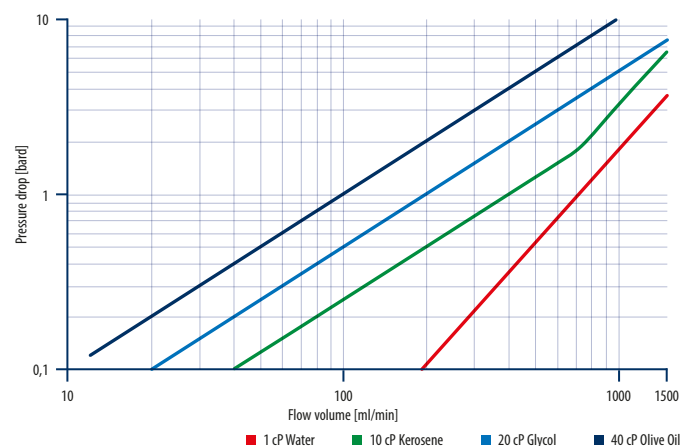

› Hygienic Flow Controller for the Food & Beverage Market

The integrated PID controller can be used to drive a control valve or pump, enabling users to establish a complete and compact control loop. In this application example the ES-FLOW™ is controlling a hygienic and 3-A authorized GEMÜ pneumatically operated diaphragm valve at a flowrate of 900 ml/min. This combination makes an excellent hygienic flow controller for a wide range of applications within the Food & Beverage market. This design is also very interesting for the process industry with challenging liquids (e.g. particles) as the risk of clogging is limited due to the hygienic design.



ES-FLOW™ flow meter with close-coupled valve; hygienic and 3-A authorized

› Batch Dosing & Counter Functionalities

One of the advantages of the ES-FLOW™ is that the instrument is equipped with an integrated counter, totalizer and batch dosing functionality. This dosing technology allows batch dosing of small amounts of liquid additives with only a minimum of tolerance. The firmware is equipped with a "learning function" to correct even the smallest tolerances automatically (e.g. during start-up of the instrument or change of supply batches). The setup is customised to fulfil all requirements of the production; it can easily be integrated in already existing processes and production lines. Moreover, with this batch dosing functionality the instrument can control shut-off valves, proportional valves and pumps.

› Flow Meter Controlled Pumps

Pumps are core components in a liquid system. Dosing or metering pumps are able to "measure" the flow of a liquid by positive displacement or rotations. Process conditions, such as temperature, air containment, back pressure and wear and tear, influence the "measured value", and therefore the pump needs an additional device to make the required correction. The ES-FLOW™ offers the opportunity for direct pump steering. Based on the desired flowrate the ES-FLOW™ controls the speed of the pump to minimise the influence of process conditions and therefore ensures high accuracy and repeatability.

› Versatile multi-purpose instrument

- ◆ Digital, Analog or Fieldbus Communication
- ◆ Readout & control by display
- ◆ Customised I/O outputs:
 - ◆ Analog control signals 0...10 Vdc, 0...20 mA controlling pumps or valves
 - ◆ Pulse, Frequency or Alarm output



Liquid Dosing Set, consisting of an ES-FLOW™ flow meter with integrated PID controller, directly driving a close-coupled pump

➤ Application example for candy production

During the manufacturing of candy, additives such as colourings, flavourings and acids have to be added to a main stream. The latter is a hot, viscous mass that usually consists of water, sugar and glucose syrup. By using our ultrasonic volume flow meters, the dosing accuracy will be improved, and so is the quality control of the manufacturing process. The below solution consists of 4 ES-FLOW™ ultrasonic flow meters. One is used to measure the main flowrate as the other instruments measure/control the flow of colouring, flavouring and acid. As these fluids are highly concentrated, only small amounts have to be added. These small amounts can be measured with the ultrasonic flow meter, as the measurement range is within 4 to 2-1500 ml/min with a precision of +/- 0.8% Rd. The overall performance and user friendly operation of the ES-FLOW™ instrument are the main reasons for choosing this device. Moreover, manufacturers of confectionery products using ES-FLOW™ devices, earned back their investments in flow meters by saving costly natural colouring and flavouring agents and large quantities of raw material. Before, when relying on volumetric dosing without flow measurement, errors in the production were detected at a rather late stage, resulting in entire batches of candy that had to be defined as 'second choice'. Using flow meters, poor quality - if any - will be detected in a much earlier stage.



ES-FLOW™ model ES-1031 with Tri-Clamp process connections

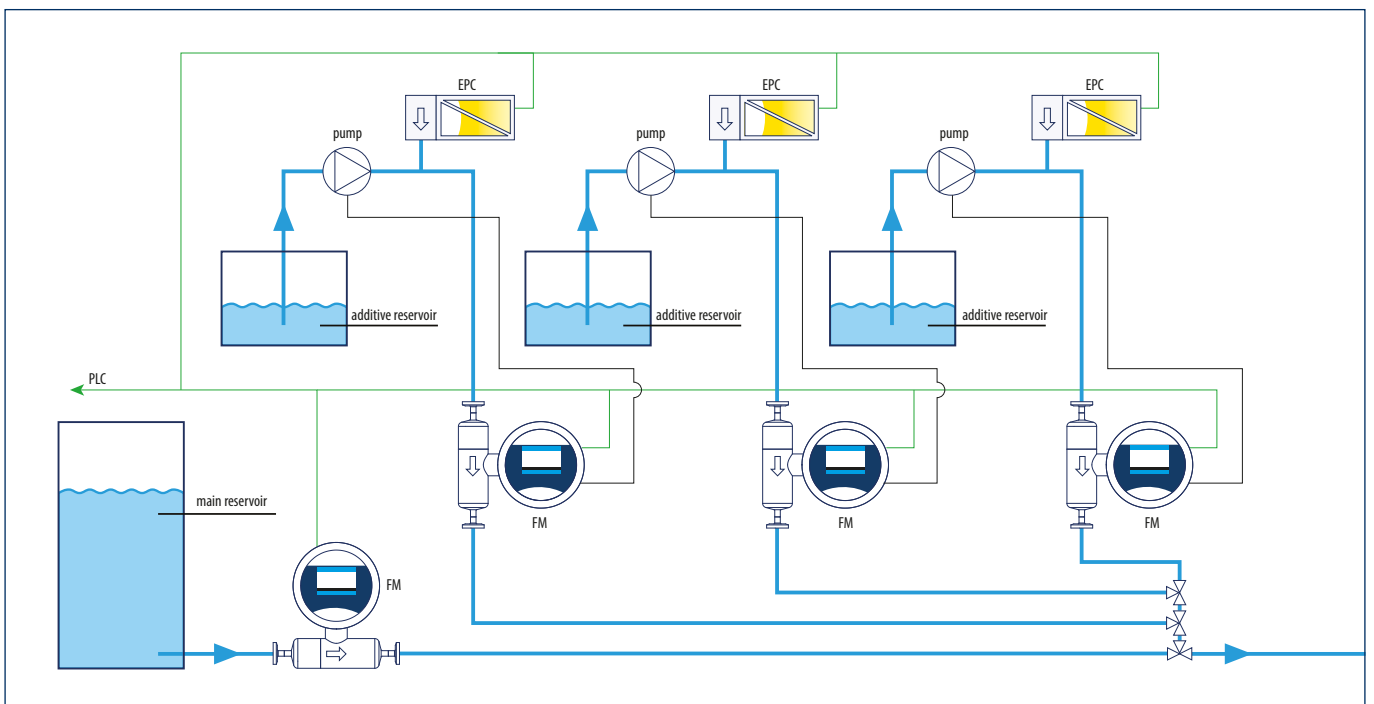

Application example for candy production

Model number identification

